

EXPE
RIENCE
LIVE STATIONS
TABLES
COUNTERS

HISTORY

1946

EN_ Deagostini Inox was founded in 1946 in Quarna Sotto by Umberto Deagostini. Initially known as “IDEA”, it was dedicated to the production of tips made in ferrous materials in order to keep clogs and shoes intact. With the advent of the tin plate, the company began to produce the first graters with a wooden handle, until becoming, in the mid-50s, one of the first Italian manufacturers of household items intended for homes, wedding lists, bars and hotels.

IT_ La Deagostini Inox fu fondata nel 1946 a Quarna Sotto da Umberto Deagostini. Inizialmente nota con il nome “IDEA”, era dedicata alla produzione di puntali in materiali ferrosi al fine di mantenere intatti zoccoli e scarpe. Con l’avvento della banda stagnata iniziò a produrre le prime grattugie con manico in legno, fino a diventare, nella metà degli anni ‘50, una tra le prime manifatture italiane di articoli per la casa destinati ad abitazioni, liste nozze, bar ed alberghi.

1958

EN_ In 1958 Umberto’s son, Sandro, joined his father in running the family business. The increased production made it indispensable to inaugurate a second plant in Omegna, on the Lake of Orta and in the 80s, thanks to the economic growth, it was necessary to move to a bigger facility that could accommodate workers and machinery. The 90s marked the beginning of the production of equipments aimed at fitting out buffet for breakfast. Among the first companies to provide these tools, Deagostini took part in the creation of the buffet breakfast service, which was then consolidated especially at international luxury facilities.

IT_ Nel 1958 il figlio di Umberto, Sandro, si unì al padre nella conduzione dell’azienda di famiglia. L’incremento produttivo rese indispensabile l’inaugurazione di un secondo stabilimento ad Omegna, sul lago d’Orta e negli anni ‘80, grazie alla crescita economica, si rese necessario il trasferimento in una struttura più grande che potesse accogliere operai e macchinari. Gli anni ‘90 segnarono l’inizio della produzione di attrezzature rivolte all’allestimento del buffet per la prima colazione. Tra le prime aziende a fornire questi strumenti, la Deagostini partecipò alla nascita del servizio di prima colazione a buffet, allora consolidato soprattutto presso strutture di lusso internazionali.

2005

EN_ In 2005 the company started the production of Live Cooking Stations, which became today a substantial component of the company’s mission. In 2009 Andrea, son of Sandro, joined the company management thus taking Deagostini to its third generation, that combined with the link between design culture and quality of materials, enhances the “Made in Italy” in a universal dimension. Nowadays, the company counts collaborations with prestigious international facilities.

IT_ Nel 2005 la compagnia intraprese il percorso della produzione di Live Cooking Stations, divenute oggi componente sostanziale della mission aziendale. Nel 2009 Andrea, figlio di Sandro, si unì alla direzione dell’azienda portando così la Deagostini alla sua terza generazione, che unita al legame tra cultura del progetto e qualità dei materiali, esalta il “Made in Italy” in una dimensione universale. Ad oggi, l’azienda annovera collaborazioni con prestigiose strutture a livello internazionale.



Umberto Deagostini

Umberto succeeded in transforming a post-war artisan reality into one of the first Italian manufacturers of household goods.

Umberto riuscì a trasformare una realtà artigianale post-guerra in una delle prime imprese italiane produttrici di casalinghi.

Sandro took the company into the international reality making it, even today, a reference name in the hotel industry.

Sandro portò l'azienda nella realtà internazionale rendendola, ancora oggi, un nome di riferimento per il settore alberghiero.

Sandro Deagostini

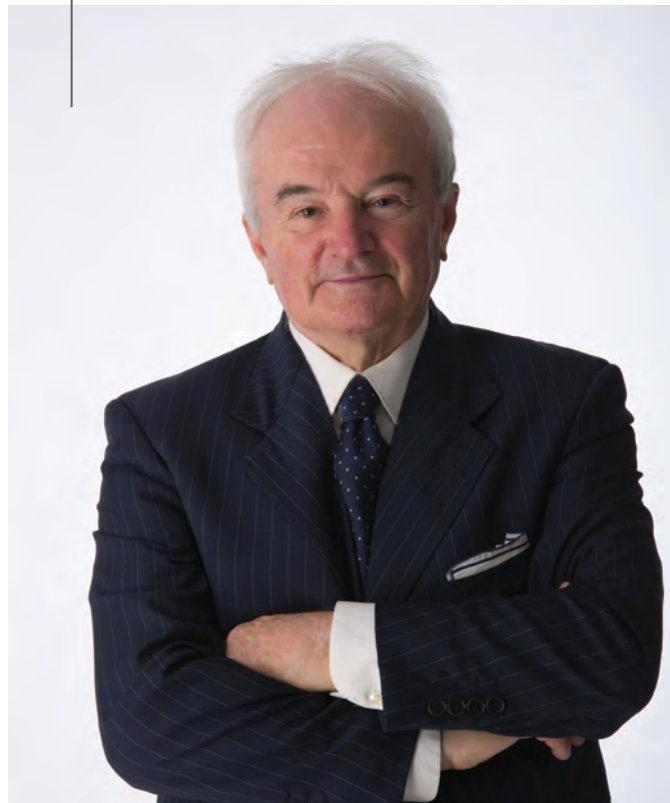

Andrea Deagostini

Andrea, passionate about design and technology, has taken the company into the modern world with energy, passion and inventiveness.

Andrea, appassionato di design e tecnologia, ha portato l'azienda nel mondo moderno con energia, passione ed inventiva.

MISSION

Functionality, technology and design have always represented Deagostini Inox company's mission.

Funzionalità, tecnologia e design rappresentano da sempre la mission aziendale della Deagostini Inox.





FUNCTIONALITY

EN_ Functionality represents the necessary condition of Deagostini products. The relationship between efficiency and form, intended as aesthetics, represents an added value that gives products beauty and appeal where form is never at the expense of function, but it rather elevates its prestige.

IT_ La funzionalità rappresenta la condizione necessaria dei prodotti Deagostini. Il rapporto tra efficienza e forma, intesa come armonia, rappresenta un valore aggiunto che conferisce ai prodotti alto valore estetico ed attrattivo dove la forma non è mai a discapito della funzione, ma anzi ne eleva il prestigio.



DESIGN

EN_ The diversified range of products, designed according to international standards of style, is the result of high-design choices, forerunner of new requirements and changes in contemporary living, thus giving a unique style.

IT_ La gamma diversificata di prodotti, disegnati su impronte stilistiche internazionali, è il frutto di scelte di alto design che permettono di anticipare le nuove esigenze e i cambiamenti stilistici contemporanei, conferendo così uno stile inconfondibile.



TECHNOLOGY

EN_ The proximity of raw materials and local knowledge guarantee traditional languages revisited in a contemporary way, where technology always remains at the service of the design criteria. Traditional materials, such as wood and steel, blend with technology, creating beautiful environments to live, practical and durable.

IT_ La vicinanza delle materie prime e le competenze locali garantiscono linguaggi della tradizione rivisitati in chiave contemporanea, dove la tecnologia rimane sempre al servizio dei criteri di progettazione. I materiali tradizionali, come il legno e l'acciaio, si fondono alla tecnologia creando ambienti belli da vivere, pratici e duraturi.

MATERIALS

EN_ An accurate selection of materials - all of Italian and European origin, guaranteed for the food industry - is one of the secrets of the excellence of Deagostini Inox's products. The manufacturing process is carefully controlled by trained staff and is entirely conducted in our factory. In addition, our collaborations with leading European producers of appliances confirm the quality of a high standard finished product. Deagostini, thanks to its role as a manufacturer, guarantees a supplied and ready service of spare parts, in order to ensure the originality and the maximum functionality of its products, even after years of use.

IT_ La scelta accurata dei materiali - tutti di origine Italiana ed Europea, garantiti per il settore alimentare - è uno dei segreti dell'eccellenza dei prodotti Deagostini Inox. Il processo produttivo è seguito scrupolosamente da personale preparato e viene interamente effettuato nei nostri stabilimenti. Inoltre, le collaborazioni con rinomati produttori europei nel settore degli elettrodomestici confermano la qualità di prodotti finiti di alto livello. La Deagostini, grazie al proprio ruolo di fabbricante, garantisce un fornito e pronto servizio di parti di ricambio, al fine di assicurare l'originalità e la massima funzionalità dei propri prodotti, anche dopo anni d'utilizzo.

ES_ La cuidadosa selección de materiales - todos de origen Italiano y Europeo, garantizados para la industria alimentaria - es uno de los secretos de la excelencia de los productos Deagostini Inox. El proceso de fabricación se controla cuidadosamente por personal capacitado y se hace enteramente en nuestra fábrica. Además, la colaboración con los fabricantes europeos líderes en electrodomésticos confirman la calidad de productos acabados de alto nivel. Deagostini, gracias a su papel como fabricante, garantiza un servicio suministrado y listo de piezas de repuesto para garantizar la originalidad y la máxima funcionalidad de sus productos, después de años de uso.

FR_ La sélection rigoureuse des matériaux - tous d'origine Italienne et Européenne, garantis pour l'industrie alimentaire - est l'un des secrets de l'excellence des produits Deagostini Inox. Le processus de fabrication est suivi scrupuleusement par du personnel formé et il est entièrement réalisé dans nos usines. Aussi, nos collaborations avec des producteurs européens renommés dans le secteur des appareils électroménagers confirment la qualité des produits finis de haut niveau. Deagostini grâce à son rôle de fabricant, garantit un service fourni et prêt de pièces de rechange, afin de garantir l'originalité et la fonctionnalité maximale de ses produits, même après des années d'utilisation.





STAINLESS STEEL 18/10-AISI 304 BRUSHED

IT_ Acciaio inossidabile 18/10-AISI 304 - Satinato

ES_ Acero inoxidable 18/10-AISI 304 - Satinado

FR_ Acier inoxydable 18/10-AISI 304 - Satiné

EN_ Rigorous in its harmonic shapes, for a linear and functional aesthetic. In addition to its design strength, its resistance makes it a valuable, long lasting and reliable material. 100% recyclable, no maintenance, corrosion resistance and mechanical features are some of the connotations that make it an essential material.

IT_ Rigoroso nelle sue forme armoniche, per un'estetica lineare e funzionale. Oltre alla sua forza progettuale, la sua resistenza lo rende un prodotto valido, duraturo e affidabile. 100% riciclabile, assenza di manutenzione, resistenza alla corrosione e caratteristiche meccaniche di rilievo sono alcune delle connotazioni che lo rendono un prodotto imprescindibile.

ES_ Riguroso en sus formas armoniosas, para una estética lineal y funcional. Además de su fuerza de diseño, su resistencia lo convierte en un producto válido, duradero y confiable. 100% reciclable, sin mantenimiento, resistencia a la corrosión y características mecánicas significativas son algunas de las connotaciones que lo convierten en un producto esencial.

FR_ Rigoureux dans ses formes harmonieuses, pour une esthétique linéaire et fonctionnelle. Sa résistance en fait un produit valide, durable et fiable. 100% recyclable, pas d'entretien, résistance à la corrosion et caractéristiques mécaniques sont des connotations qui en font un produit essentiel.



STAINLESS STEEL 18/10-AISI 304 MIRROR FINISH

IT_ Acciaio inossidabile 18/10-AISI 304 - Lucidato a specchio

ES_ Acero inoxidable 18/10-AISI 304 - Acabado espejo

FR_ Acier inoxydable 18/10-AISI 304 - Poli miroir

EN_ 100% recyclable, long lasting and with mechanical features that ensure lack of maintenance, corrosion resistance and sustainability. Bright finishes make details accurate and distinctive.

IT_ 100% riciclabile, duraturo e con caratteristiche meccaniche di rilievo che garantiscono assenza di manutenzione, resistenza alla corrosione e durevolezza. Le finiture brillanti rendono i dettagli accurati e distintivi.

ES_ 100% reciclable, duradero y con características mecánicas de alivio que aseguran el mantenimiento, la resistencia a la corrosión y la durabilidad. Los brillantes acabados hacen que los detalles sean precisos y distintivos.

FR_ 100% recyclable, durable et avec des caractéristiques mécaniques de relief qui assurent aucun entretien, résistance à la corrosion et durabilité. Les finitions brillantes rendent les détails précis et distinctifs.

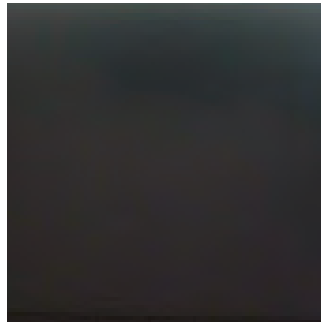

WOOD

WALNUT NATURAL COLOR / BLACK COLOR

IT_ Legno – Tinta noce naturale/Tinta nera

ES_ Madera – Color natural de nogal/Color negro

FR_ Bois – Couleur noyer nature/Couleur noir

EN_ Warm and cozy, it creates a sophisticated game of references between the past and the present, tradition and innovation. Marked by high value and natural finishes. Strong, compact, long lasting and easy to clean. It is the distinctive feature of every project.

IT_ Caldo e accogliente, crea un sofisticato gioco di rimandi tra passato e presente, tradizione ed innovazione. Di grande pregio e dalle finiture naturali. Robusto, compatto, longevo e di facile pulizia. Rappresenta un segno distintivo ed estremamente caratterizzante di ogni progetto.

ES_ Cálido y acogedor, crea un sofisticado juego de referencias entre el pasado y el presente, la tradición y la innovación. De gran valor y acabados naturales. Robusto, compacto, duradero y fácil de limpiar. Representa un signo distintivo y extremadamente característico de cada proyecto.

FR_ Chaleureux et accueillant, crée un jeu sophistiqué de références entre passé et présent, tradition et innovation. De grand valeur et avec finitions naturelles. Robuste, compact, durable et facile à nettoyer. Il représente un signe fort et caractéristique de chaque projet.

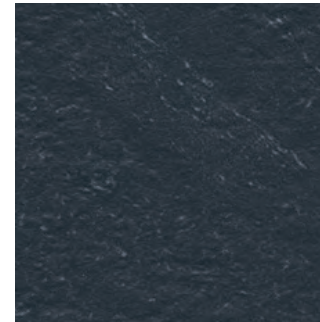

HIGH PRESSURE LAMINATE LAYERED

IT_ Laminato ad alta pressione – Multistrato

ES_ Laminado de alta presión – Multicapas

FR_ Stratifié haute pression – Multicouche

EN_ Revolution and innovation in an excellent material thanks to its functional and aesthetic potentialities. Anti-scratch, waterproof, resistant to oils, steam and water. Unalterable up to 60°, anti bacterial and long lasting.

IT_ Rivoluzione ed innovazione in un materiale eccellente per le sue potenzialità funzionali ed estetiche. Anti-graffio, impermeabile, resiste ad oli, vapore ed acqua. Inalterabile fino a 60°, anti batterico e duraturo.

ES_ Revolución e innovación en un material excelente por sus potencialidades funcionales y estéticas. Anti-rasguños, impermeable, resistente a aceites, vapor y agua. Inalterable hasta 60°, antibacteriano y de larga duración.

FR_ Révolution et innovation dans un excellent matériau pour ses potentialités fonctionnelles et esthétiques. Anti-rayures, imperméable, résistant aux huiles, à la vapeur et à l'eau. Inaltérable jusqu'à 60°, anti bactérien et durable.



POLYCARBONATE

IT_ Policarbonato
ES_ Policarbonato
FR_ Polycarbonate

EN_ Extremely versatile, excellent for the creation of functional and aesthetically pleasing long lasting products. Recyclability, resistance, heat and shape stability make it one of the most required thermoplastic materials for new applications.

IT_ Estremamente versatile, eccellente per la creazione di prodotti funzionali ed esteticamente piacevoli, nonché durevole nel tempo. Riciclabilità, resistenza, stabilità termica e dimensionale lo rendono uno dei materiali termoplastici maggiormente richiesti per le nuove applicazioni.

ES_ Extremadamente versátil, excelente para la creación de productos funcionales, estéticamente agradables y duradero. Reciclabilidad, resistencia, estabilidad térmica y dimensional lo convierten en uno de los materiales termoplásticos más populares para las nuevas aplicaciones.

FR_ Polyvalent, excellent pour la création des produits fonctionnels et esthétiques, durable. Recyclabilité, résistance, stabilité thermique et dimensionnelle en font un des produits thermoplastiques les plus populaire pour les nouvelles applications.

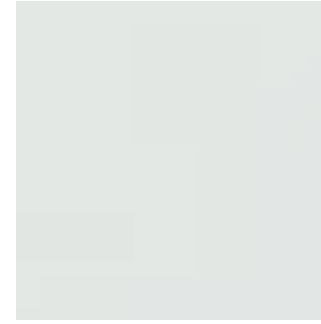

TEMPERED GLASS

IT_ Vetro temperato
ES_ Vidrio templado
FR_ Verre trempé

EN_ Pure and shiny, healthy and eco-friendly. Easy to clean and abrasion resistant. The charm of this precious material lies in its ability to show and separate, to contain and reveal at the same time.

IT_ Puro e luminoso, sano ed ecosostenibile. Di facile pulizia e resistente alle abrasioni. Il fascino di questo prezioso minerale risiede nella sua capacità di mostrare e separare, di contenere e rivelare allo stesso tempo.

ES_ Puro y brillante, saludable y eco-sostenible. Fácil de limpiar y resistente a la abrasión. El encanto de este mineral precioso reside en su capacidad de mostrar y separar, de contener y revelar al mismo tiempo.

FR_ Pur et lumineux, sain et écodurable. Facile à nettoyer et résistant à l'abrasion. Le charme de ce précieux matériel est la capacité à montrer et séparer, à contenir et à révéler en même temps.

LOCATION

EN_ Our company is located in Omegna (VB), 50 Km from Switzerland and 100 Km from Milan.

IT_ La nostra azienda si trova ad Omegna (VB), a 50 Km dalla Svizzera e a 100 Km da Milano.

ES_ Nuestra empresa se encuentra en Omegna (VB), a 50 Km de Suiza y 100 Km de Milán.

FR_ Notre entreprise se trouve à Omegna (VB), à 50 Km de la Suisse et a 100 Km de Milan.



KEY



Refrigerated by cooling pack
Raffreddamento con piastra eutettica
Refrigerado por acumulador térmico
Refroidissement avec pain de glace



Refrigerated by ice cubes
Raffreddamento con cubetti di ghiaccio
Refrigerado por cubitos de hielo
Refroidissement avec glaçons



Refrigerated
Refrigerato
Refrigerado
Réfrigéré



Spout
Rubinetto di scarico
Grifo de descarga
Robinet de vidange



Electric resistance feeding
Alimentazione con resistenza elettrica
Alimentación con resistencia eléctrica
Alimentation avec résistance électrique



Electric current feeding
Alimentazione a corrente elettrica
Alimentación a corriente eléctrica
Alimentation électrique



Bain marie
Bagno maria
Baño maria
Bain-marie



Induction feeding
Alimentazione a induzione
Alimentación con inducción
Alimentation avec induction



Customizable item
Articolo realizzabile su misura
Artículo realizable por encargo
Article réalisable sur mesure



Grid for drain
Griglia per drenaggio
Parilla por drenaje
Grille pour drainage



Adjustable clutch
Frizione regolabile
Fricción regulable
Friction réglable



GN 1/1 GN 1/1



GN 2/3 GN 2/3



GN 6/1 GN 6/1



Gas bottle
Bombola gas
Cilindro de gas
Bouteille de gaz



Gas feeding
Alimentazione a gas
Alimentación con gas
Alimentation à gaz



Recyclable material
Materiale riciclabile
Material reciclable
Matériau recyclable



Suitable for food contact
Adatto al contatto con gli alimenti
Adapto para contacto alimentario
Convenient au contact alimentaire



MADE IN ITALY



INDEX



TABLES

PAG. 16

breakfast.....	22
cook & self service ...	42
neo	50
star	54
moon.....	58
smart.....	66
domino	70



COUNTERS

PAG. 74

tetris	82
idea	94
double	102



LIVE COOKING & COCKTAIL STATIONS PAG. 112

evolution	118
showcooking	136
cube	148
new cube	156
naked	174

tables

A complete range of buffet equipments on compatible and modular tables, that can be placed side by side and equipped in infinite combinations to meet the needs of fixed and mobile catering.

A modern and professional banqueting and foodservice system: functional, technological and of design.

IT_ Una gamma completa di apparecchiature da buffet su tavoli compatibili e modulari, che possono essere affiancati e attrezzati in infinite combinazioni per soddisfare le esigenze della ristorazione fissa e mobile.

Un moderno e professionale sistema di banqueting e foodservice: funzionale, tecnologico e di design.

ES_ Una gama completa de equipos de buffet mesas compatibles y modulares, que pueden colocarse una al lado de la otra y equipadas en infinitas combinaciones para satisfacer las necesidades de la restauración fija y móvil.

Un moderno y profesional sistema de banquetes y servicios gastronómicos: funcional, tecnológico y de design.

FR_ Une gamme complète d'équipements de buffet sur tables compatibles et modulaires, qui peuvent être placés côte à côte et équipés dans une infinité de combinaisons pour répondre aux besoins de la restauration fixe et mobile.

Un système de réception et de restauration moderne et professionnel: fonctionnel, technologique et de conception.





Functionality, Technology and Design.



High pressure laminate - Layered

- IT_* Laminato ad alta pressione - Multistrato
ES_ Laminado de alta presión - Multicapas
FR_ Stratifié haute pression - Multicouche

- EN_* Revolution and innovation in an excellent material thanks to its functional and aesthetic potentialities. Anti-scratch, waterproof, resistant to oils, steam and water. Unalterable up to 60°, anti bacterial and long lasting.**
- IT_* Rivoluzione ed innovazione in un materiale eccellente per le sue potenzialità funzionali ed estetiche. Anti-graffio, impermeabile, resiste ad oli, vapore ed acqua. Inalterabile fino a 60°, anti batterico e duraturo.
- ES_* Revolución e innovación en un material excelente por sus potencialidades funcionales y estéticas. Anti-rasguños, impermeable, resistente a aceites, vapor y agua. Inalterable hasta 60°, antibacteriano y de larga duración.
- FR_* Révolution et innovation dans un excellent matériau pour ses potentialités fonctionnelles et esthétiques. Anti-rayures, imperméable, résistant aux huiles, à la vapeur et à l'eau. Inaltérable jusqu'à 60°, anti bactérien et durable.

- EN_* A supporting structure only partially embedded in the surface of the table, to ensure stability and flow, without neglecting the elegance guaranteed by the mirror-polished stainless steel.**
- IT_* Una struttura portante solo parzialmente incassata nella superficie del tavolo, per assicurare stabilità e portata, senza trascurare l'eleganza garantita dall'acciaio inossidabile lucidato a specchio.
- ES_* Una estructura de soporte solo parcialmente incrustada en la superficie de la mesa, para garantizar la estabilidad y el flujo, sin descuidar la elegancia garantizada por el acero inoxidable acabado espejo.
- FR_* Une structure de support seul partiellement encastrée dans la surface du table, pour assurer la stabilité et la fluidité, sans pour autant négliger l'élégance garantie par l'acier inoxydable poli miroir.

Stainless steel 18/10-AISI 304 Mirror finis

- IT_* Acciaio inossidabile 18/10-AISI 304 - Lucidato a specchio
ES_ Acero inoxidable 18/10-AISI 304 - Acabado espejo
FR_ Acier inoxydable 18/10-AISI 304 - Poli miroir

- EN_* 100% recyclable, long lasting and with mechanical features that ensure lack of maintenance, corrosion resistance and sustainability. Bright finishes make details accurate and distinctive.**
- IT_* 100% riciclabile, duraturo e con caratteristiche meccaniche di rilievo che garantiscono assenza di manutenzione, resistenza alla corrosione e durevolezza. Le finiture brillanti rendono i dettagli accurati e distintivi.
- ES_* 100% reciclable, duradero y con características mecánicas de alivio que aseguran el mantenimiento, la resistencia a la corrosión y la durabilidad. Los brillantes acabados hacen que los detalles sean precisos y distintivos.
- FR_* 100% recyclable, durable et avec des caractéristiques mécaniques de relief qui assurent aucun entretien, résistance à la corrosion et durabilité. Les finitions brillantes rendent les détails précis et distinctifs.

Breakfast / Cook / Self service



1
Made of poplar wood covered with 9/10 high pressure laminate.

IT_ Realizzati in legno di pioppo rivestito da laminato ad alta pressione da 9/10.

ES_ Hecho en madera de álamo revestido de laminado de alta presión de 9/10.

FR_ Fabriqués en bois de peuplier recouvert en stratifié haute pression de 9/10.

2
Structure made in 18/10-AISI 304 mirror finish stainless steel.

IT_ Struttura realizzata in acciaio inossidabile 18/10-AISI 304 lucidato a specchio.

ES_ Estructura hecha en acero inoxidable 18/10-AISI 3014 acabado espejo.

FR_ Structure réalisée en acier inoxydable 18/10-AISI 304 poli miroir.

3
Equipped with 4 pivoting, nonmarking wheels with brakes, to facilitate service maneuvers and storage.

IT_ Muniti di 4 ruote pivotanti, antitraccia e dotate di freno, per facilitare la manovre di servizio e stoccaggio.

ES_ Equipado con 4 ruedas rotatorias, antihuella y provista de frenos, para facilitar las maniobras de servicio y almacenamiento.

FR_ Equipé de 4 roues pivotantes, non marquantes avec freins, pour faciliter les manœuvres d'entretien et stockage.

Tables can be customized with a wide range of colours available.

IT_ I tavoli possono essere personalizzati con una vasta gamma di colori disponibili.

ES_ Las mesas se pueden personalizar con una amplia gama de colores disponibles.

FR_ Les tables peuvent être personnalisées avec une large gamme de couleurs disponibles.

finishe

MATT



W1
white ice

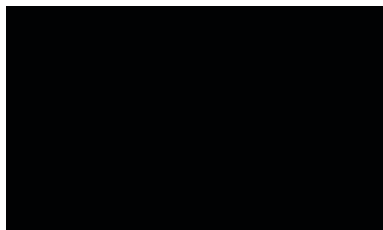

B1
black

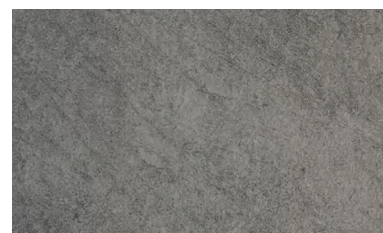

C2
walkprint

CLIMB

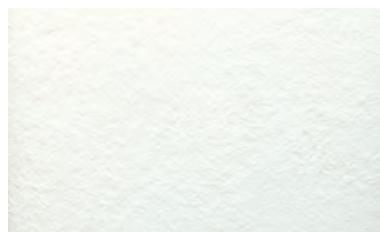

W5
white climb

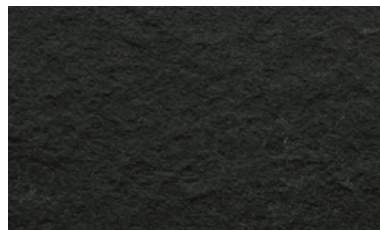

B2
black ardesia



C1
greige

MOD ULTRA MATT

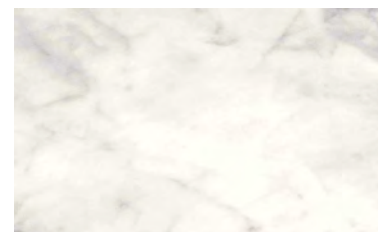

W2
statuario

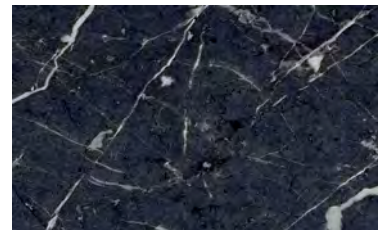

B6
alicante

Customization of all tables on request. Contact our sales office .

Some examples

We propose, here following, some examples of customization that can be applied to tables.

IT_ Proponiamo a seguire alcuni esempi di personalizzazione che possono essere applicati ai tavoli.

ES_ Proponemos a seguir algunos ejemplos de personalización que se pueden aplicar a las mesas.

FR_ Nous vous proposons de suivre quelques exemples de personnalisation qui pouvant être appliqués aux tables.

***EN_* Deagostini Inox offers its customers a personalized design service.**

Contact our sales office and request a customized proposal regarding products, finishes colours and technical equipment.

The technical office is at our disposal to combine our range of proposals based on your needs!

IT_ La Deagostini Inox offre ai propri clienti un servizio di progettazione personalizzato. Contatta il nostro ufficio vendite e richiedi una proposta su misura in merito a prodotti, finiture, colori e attrezzature tecniche.

L'ufficio tecnico è a tua disposizione per combinare la nostra gamma di proposte in base alle tue esigenze!

ES_ Deagostini Inox ofrece a sus clientes un servicio de design personalizado.

Póngase en contacto con nuestra oficina de ventas y solicite una propuesta personalizada en cuanto a productos, acabados, colores y equipos técnicos.

La oficina técnica está a su disposición para combinar nuestra gama de propuestas según sus necesidades!

FR_ Deagostini Inox propose à ses clients un service de design sur mesure.

Contactez notre bureau des ventes et demandez une proposition personnalisée concernant les produits, les finitions, les couleurs et les équipements techniques.

Le bureau technique est à votre disposition pour combiner notre gamme de propositions en fonction de vos besoins!



breakfast



Basic models are available in three different sizes and can be used neutral or equipped with a wide range of appliances and optional.

IT_ I modelli base sono disponibili in tre differenti misure e possono essere utilizzati neutri oppure equipaggiati con una vasta gamma di applicazioni ed optional.
ES_ Los modelos básicos están disponibles en tres tamaños diferentes y pueden utilizarse de manera neutral o equipados con una amplia gama de aplicaciones y opcionales.
FR_ Les modèles de base sont disponibles en trois tailles différentes et peuvent être utilisés neutres ou équipés d'un large éventail d'applications et d'optionals.



Table sizes

ART. BREAKFAST 160
cm 160x80x(h)82

ART. BREAKFAST 210
cm 210x80x(h)82

ART. BREAKFAST 250
cm 250x80x(h)82

Polycarbonate protection.

IT_ Protezione in policarbonato.

ES_ Protección en policarbonato.

FR_ Protection en polycarbonate.

SIZE: cm 206 - h cm 55



ART. BREAKFAST 210/B2/X1
cm 210x80x(h)82+55



ART. BREAKFAST 250/B2/X1
cm 250x80x(h)82+55



Tabletop for plates on both sides.

IT_ Piano d'appoggio per piatti su ambo i lati.

ES_ Llano de apojo para platos en ambos lados.

FR_ Dessus de table pour assiettes des deux côtés.



ART. X1

EN_ Neutral polycarbonato protection.

IT_ Protezione neutra in policarbonato.

ES_ Protección neutra de policarbonato.

FR_ Protection neutre en polycarbonate.



ART. Y1

EN_ Polycarbonato protection with LED lighting.

IT_ Protezione in policarbonato con illuminazione LED.

ES_ Protección de policarbonato con iluminación LED.

FR_ Protection en polycarbonate avec éclairage LED.



ART. Z1

EN_ Polycarbonato protection with heating lamp.

Only to be combined with appliance Art. HOT53.

IT_ Protezione in policarbonato con lampada riscaldante.

Abbinabile solo all'applicazione Art. HOT 53.

ES_ Protección de policarbonato con lámpara de calentamiento.

Para ser combinado solo con l'applicacion Art. HOT53.

FR_ Protection en polycarbonate avec lampe chauffante.

Combinable seulement avec l'application Art. HOT53.

See page 40.

Tempered glass protection and plates holder.

IT_ Protezione e appoggio per piatti in vetro temperato.

ES_ Protección y soporte de platos de vidrio templado.

FR_ Protection et porte-assiettes en verre trempé.

SIZE: cm 206 - h cm 50



ART. BREAKFAST 210/B2/X2
cm 210x80x(h)82+50



ART. BREAKFAST 250/B2/X2
cm 250x80x(h)82+50



ART. X2

EN_ Neutral tempered glass protection and plates holder.

IT_ Protezione e appoggio per piatti neutro in vetro temperato.

ES_ Protección y soporte de platos neutro de vidrio templado.

FR_ Protection et porte-assiettes neutre en verre trempé.



ART. Y2

EN_ Tempered glass protection and plates holder with LED lighting.

IT_ Protezione e appoggio per piatti in vetro temperato con illuminazione LED.

ES_ Protección y soporte de platos de vidrio templado con iluminación LED.

FR_ Protection et porte-assiettes en verre trempé avec éclairage LED.



ART. BREAKFAST 210/B2/HOT53/X1



ART. BREAKFAST 250/B2/HOT53/X1

colours available	matt finish	W1	B1	C2
	climb finish	W5	B2	C1
	ultra matt finish	W2	B6	

Optional

Neutral polycarbonate protection.

IT_ Protezione neutra in policarbonato.

ES_ Protección neutra de policarbonato.

FR_ Protection neutre en polycarbonate.

Table equipped with 18/10-AISI 304 stainless steel heating plate.

Adjustable temperature from +30 to +90°C.

6 GN 1/1 - cm 194x52 - 200W - 230V - 50/60Hz.



ART. BREAKFAST 210/B2/HOT53

IT_ Tavolo equipaggiato con piano caldo in acciaio inossidabile 18/10-AISI 304.

ES_ Mesa equipada con placa calentadora en acero inoxidable 18/10-AISI 304.

FR_ Table équipé du plateau chauffante en acier inoxydable 18/10-AISI 304.



ART. BREAKFAST 210/B2/COL56/X1



ART. BREAKFAST 250/B2/COL56/X1

colours available	matt finish	W1	B1	C2
	climb finish	W5	B2	C1
	ultra matt finish	W2	B6	

Optional

Neutral polycarbonate protection.

IT_ Protezione neutra in polycarbonato.

ES_ Protección neutra de polycarbonato.

FR_ Protection neutre en polycarbonate.

Table equipped with refrigerated 18/10-AISI 304 stainless steel basin.

Adjustable temperature from -5 to +8°C.

6 GN 1/1 - cm 205x63 - 256W - 220V - 50Hz.



GN 6/1



ART. BREAKFAST 210/B2/COL56

IT_ Tavolo equipaggiato con vasca refrigerata in acciaio inossidabile 18/10-AISI 304.

ES_ Mesa equipada con cubeta refrigerada de acero inoxidable 18/10-AISI 304.

FR_ Table équipé de bac réfrigérée en acier inoxydable 18/10-AISI 304.



ART. BREAKFAST 210/B2/COL55/HOT52/X1



ART. BREAKFAST 250/B2/COL55/HOT52/X1

colours available	matt finish	W1	B1	C2
	climb finish	W5	B2	C1
	ultra matt finish	W2	B6	

Optional

Neutral polycarbonate protection.

IT_ Protezione neutra in polycarbonato.

ES_ Protección neutra de polycarbonato.

FR_ Protection neutre en polycarbonate.

Table equipped with refrigerated 18/10-AISI 304 stainless steel basin and heating plate.



**EN_ Refrigerated 18/10-AISI 304 stainless steel basin.
3 GN 1/1 - cm 106x62 - 350W.**

IT_ Vasca refrigerata in acciaio inossidabile 18/10-AISI 304.

ES_ Cubeta refrigerada de acero inoxidable 18/10-AISI 304.

FR_ Bac réfrigérée en acier inoxydable 18/10-AISI 304.

IT_ Tavolo equipaggiato con vasca refrigerata e piano caldo in acciaio inossidabile.

ES_ Mesa equipada con cubeta refrigerada y placa calentadora en acero inoxidable.

FR_ Table équipée de bac réfrigérée et plateau chauffante en acier inoxydable.



**EN_ 18/10-AISI 304 stainless steel heating plate.
Adjustable temperature from +30 to +90°C.
2 GN 1/1 - cm 69x62 - 600W - 230V - 50/60Hz.**

IT_ Piano caldo in acciaio inossidabile 18/10-AISI 304.

ES_ Placa calentadora en acero inoxidable 18/10-AISI 304.

FR_ Plateau chauffante en acier inoxydable 18/10-AISI 304.



ART. BREAKFAST 210/B2/COL55/HOT52

Table equipped with induction glass-ceramic tabletop heat-retaining unit.

cm 80x40 - 230V - 1,5kW.



IT_ Tavolo equipaggiato con unità di mantenimento del calore ad induzione in vetroceramica.

ES_ Mesa equipada con unidad de calentamiento por inducción en vidrio cerámica.

FR_ Table équipée d'unité de chauffage par induction en vitrocéramique.



ART. BREAKFAST 250/B2/IND51/X1



ART. BREAKFAST 210/B2/IND51

colours available	matt finish	W1	B1	C2
	climb finish	W5	B2	C1
	ultra matt finish	W2	B6	

Optional

Neutral polycarbonate protection.

IT_ Protezione neutra in policarbonato.

ES_ Protección neutra de policarbonato.

FR_ Protection neutre en polycarbonate.

Some examples



ART. BREAKFAST 210/B2/IND51/IND51/X1

Table equipped with two induction glass-ceramic tabletop heat-retaining unit. 2x cm 80x40 - 230V - 1,5kW.











IT_ Tavolo equipaggiato con due unità di mantenimento del calore ad induzione in vetroceramica.

ES_ Mesa equipada con dos unidades de calentamiento por inducción en vidrio cerámica.

FR_ Table équipée de deux unités de chauffage par induction en vitrocéramique.



ART. BREAKFAST 210/B2/IND51/IND51

colours available	matt finish	 W1	 B1	 C2
	climb finish	 W5	 B2	 C1
	ultra matt finish	 W2	 B6	

Optional

Neutral polycarbonate protection.

IT_ Protezione neutra in polycarbonato.

ES_ Protección neutra de polycarbonato.

FR_ Protection neutre en polycarbonate.

Table equipped with two refrigerated glass-ceramic tabletop.

Adjustable temperature from -5 to +15°C.
2x 2 GN 1/1 - cm 53x66 - 170W - 50/60Hz.



IT_ Tavolo equipaggiato con due piani refrigerati in vetroceramica.
ES_ Mesa equipada con dos tapas refrigerada de vidrio cerámica.
FR_ Table équipé de deux plateau réfrigéré en vitrocéramique.



ART. BREAKFAST 210/B2/COL54/COL54/X1

colours available	matt finish	W1	B1	C2
	climb finish	W5	B2	C1
	ultra matt finish	W2	B6	

Optional

Neutral polycarbonate protection.

IT_ Protezione neutra in polycarbonato.

ES_ Protección neutra de polycarbonato.

FR_ Protection neutre en polycarbonate.

Some examples

Table equipped with tabletop heat-retaining unit and refrigerated glass-ceramic top.



ART. BREAKFAST 250/B2/IND51/COL54/X2

- IT_* Tavolo equipaggiato con unità di mantenimento del calore ad induzione in vitroceramica e piano refrigerato in vitroceramica.
ES_ Mesa equipada de unidad de retención de calor y tapa refrigerada de vidrio cerámica.
FR_ Table équipé d'unité de rétention de chaleur et plateau réfrigéré en vitrocéramique.



EN_ Refrigerated glass-ceramic top. Adjustable temperature from -5 to +15°C.

- IT_* Piano refrigerato in vitroceramica.
ES_ Tapa refrigerada de vitrocerámica.
FR_ Plateau réfrigéré en vitrocéramique.

2 GN 1/1 - cm 53x66 - 170W - 50/60Hz.



EN_ Induction glass-ceramic tabletop heat-retaining unit.

- IT_* Unità di mantenimento del calore ad induzione in vitroceramica.
ES_ Unidad de mentienimento de calor por inducción de vitrocerámica.
FR_ Unité de chauffage par induction en vitrocéramique.

cm 80x40 - 230V - 1,5kW

colours available	matt finish	W1	B1	C2
	climb finish	W5	B2	C1
	ultra matt finish	W2	B6	

Optional

Neutral tempered glass protection.

- IT_* Protezione neutra in vetro temperato. *ES_* Protección neutra de vidrio templado. *FR_* Protection neutre en verre trempé.

Table equipped with induction glass-ceramic tabletop heat-retaining unit.

2X cm 39X39 - 2X cm 52X32 - 230V - 3,2kW.



IT_ Tavolo equipaggiato con unità di mantenimento del calore ad induzione in vitroceramica.

ES_ Mesa equipada con unidad de mantenimiento del calor por inducción de vitrocerámica.

FR_ Table équipée d'unité de chauffage par induction en vitrocéramique.



ART. BREAKFAST 210/B2/IND50/X1



ART. BREAKFAST 210/B2/IND50

colours available	matt finish	W1	B1	C2
	climb finish	W5	B2	C1
	ultra matt finish	W2	B6	

Optional

Neutral polycarbonate protection.

IT_ Protezione neutra in polycarbonato.

ES_ Protección neutra de polycarbonato.

FR_ Protection neutre en polycarbonate.

Some examples

Table equipped with two 18/10-AISI 304 stainless steel ice basins.

2 GN 1/1 - cm 41x62 - depth cm 10,9.

3 GN 1/1 - cm 106x62 - depth cm 10,9.



GN 3/1

GN 2/1



IT_ Tavolo equipaggiato di due vasche per ghiaccio in acciaio inossidabile 18/10-AISI 304.





ES_ Mesa equipada de dos cubetas para hielo en acero inoxidable 18/10-AISI 304.

FR_ Table équipé de deux bacs à glace en acier inoxydable 18/10-AISI 304.



ART. BREAKFAST 210/B2/ICE57/ICE58

colours available	matt finish	W1	B1	C2
	climb finish	W5	B2	C1
	ultra matt finish	W2	B6	



Appliances available:

HOT MAINTENANCE APPLIANCES	Appliances	Code	Description			Technical info	cm 160x80x(h)82	cm 210x80x(h)82	cm 250x80x(h)82	
		IND50	EN_ Induction glass-ceramic tabletop heat-retaining unit. Remote control.	IT_ Unità di mantenimento del calore ad induzione in vetroceramica. Comando remoto.	ES_ Unidad de mantenimiento de calor por inducción de vitrocerámica. Comando a distancia.	FR_ Unité de chauffage par induction en vitrocéramique. Commande à distance.	2x cm 39x39 2x cm 52x32 230V - 3,2kW		●	●
		IND51	EN_ Induction glass-ceramic tabletop heat retaining unit. Remote control.	IT_ Unità di mantenimento del calore ad induzione in vetroceramica. Comando remoto.	ES_ Unidad de mantenimiento de calor por inducción de vitrocerámica. Comando a distancia.	FR_ Unité de chauffage par induction en vitrocéramique. Commande à distance.	cm 80x40 230V - 1,5kW	●	●	●
		HOT52	EN_ 18/10-AISI 304 stainless steel heating plate. Adjustable temperature from +30 to +90°C. Remote control.	IT_ Piano caldo in acciaio inossidabile 18/10-AISI 304. Temperatura regolabile da +30 a +90°C. Comando remoto.	ES_ Placa calentadora en acero inoxidable 18/10-AISI 304. Temperatura regulable de +30 a +90°C. Comando a distancia.	FR_ Plateau chauffante en acier inoxydable 18/10-AISI 304. Température réglable de +30 à +90°C. Commande à distance.	2 GN 1/1 cm 70x58x(H)7 800W - 230V - 50/60Hz	●	●	●
		HOT53	EN_ 18/10-AISI 304 stainless steel heating plate. Adjustable temperature from +30 to +90°C. Remote control.	IT_ Piano caldo in acciaio inossidabile 18/10-AISI 304. Temperatura regolabile da +30 a +90°C. Comando remoto.	ES_ Placa calentadora en acero inoxidable 18/10-AISI 304. Temperatura regulable de +30 a +90°C. Comando a distancia.	FR_ Plateau chauffante en acier inoxydable 18/10-AISI 304. Température réglable de +30 à +90°C. Commande à distance.	6 GN 1/1 cm 194x52x(H)7 1600W - 230V - 50/60Hz		●	●

COLD MAINTENANCE APPLIANCES

Appliances	Code	Description				Technical info	cm 160x80x(h)82	cm 210x80x(h)82	cm 250x80x(h)82
	COL54	EN_ Refrigerated glass-ceramic tabletop. Adjustable temperature from -5 to +15°C. Remote control.	IT_ Piano refrigerato in vitroceramica. Temperatura regolabile da -5 a +15°C. Comando remoto.	ES_ Placa de vidrio ceramica refrigerada. Temperatura regulable de -5 a +15°C. Comando a distancia.	FR_ Plateau réfrigéré en vitrocéramique. Température réglable de -5 à +15°C. Commande à distance.	2 GN 1/1 cm 53x66 170W - 230V - 50/60Hz	●	●	●
	COL55	EN_ Refrigerated 18/10-AISI 304 stainless steel basin. Remote control.	IT_ Vasca refrigerata in acciaio inossidabile 18/10-AISI 304. Comando remoto.	ES_ Cubeta refrigerada de acero inoxidable 18/10-AISI 304. Comando a distancia.	FR_ Bac réfrigérée en acier inoxydable 18/10-AISI 304. Commande à distance.	3 GN 1/1 cm 106x62 depth cm 3 350W - 220V - 50Hz	●	●	●
	COL56	EN_ Refrigerated 18/10-AISI 304 stainless steel basin. Adjustable temperature from -5 to +8°C. Remote control.	IT_ Vasca refrigerata in acciaio inossidabile 18/10-AISI 304. Temperatura regolabile da -5 a +8°C. Comando remoto.	ES_ Cubeta refrigerada de acero inoxidable 18/10-AISI 304. Temperatura regulable de -5 a +8°C. Comando a distancia.	FR_ Bac réfrigérée en acier inoxydable 18/10-AISI 304. Température réglable de -5 à +8°C. Commande à distance.	6 GN 1/1 cm 205x63 depth cm 3 256W - 220V - 50Hz		●	●

ICE BASINS

Appliances	Code	Description				Technical info	cm 160x80x(h)82	cm 210x80x(h)82	cm 250x80x(h)82
	ICE57	EN_ 18/10-AISI 304 stainless steel ice basin.	IT_ Vasca per ghiaccio in acciaio inossidabile 18/10-AISI 304.	ES_ Cubeta para hielo en acero inoxidable 18/10-AISI 304.	FR_ Bac à glace en acier inoxydable 18/10-AISI 304.	2 GN 1/1 cm 62x74 depth cm 10,9	●	●	●
	ICE58	EN_ 18/10-AISI 304 stainless steel ice basin.	IT_ Vasca per ghiaccio in acciaio inossidabile 18/10-AISI 304.	ES_ Cubeta para hielo en acero inoxidable 18/10-AISI 304.	FR_ Bac à glace en acier inoxydable 18/10-AISI 304.	3 GN 1/1 cm 106x62 depth cm 10,9	●	●	●

COOK & self service



This collection represents the perfect union between a professional kitchen and the self-service. The large tabletop guarantees a direct contact that will allow not only the customer to be able to take part in the culinary preparation, but also the Chef to carry out his art with manageability and speed. These tables represent the perfect product of presentation and service.

IT_ Questa collezione rappresenta la perfetta unione tra una cucina professionale e il servizio self-service. Il grande piano d'appoggio garantisce un servizio diretto che permetterà non solo al cliente di poter prendere parte alla preparazione culinaria, ma anche allo Chef di poter svolgere la propria arte con maneggevolezza e velocità. Questi tavoli rappresentano il prodotto perfetto di presentazione e servizio.

ES_ Esta colección representa la unión perfecta entre una cocina profesional y el servicio de self-service. La gran superficie de la mesa asegura un contacto directo que permitirá que no solo el cliente pueda participar en la preparación culinaria, sino también que el Chef pueda llevar a cabo su arte con facilidad y rapidez. Estas mesas representan el producto perfecto de presentación y servicio.

FR_ Cette collection représente l'union parfaite entre une cuisine professionnelle et le service self-service. Le grand plateau de table assure un service direct qui permettra non seulement au client de participer à la préparation culinaire, mais également au Chef cuisinier de pouvoir exercer son art avec simplicité et rapidité. Ces tables représentent le produit parfait de présentation et de service.



Basic models are available in three different sizes and can be used neutral or equipped with a wide range of appliances and optional.

IT_ I modelli di base sono disponibili in tre differenti misure e possono essere utilizzati neutri oppure equipaggiati con una vasta gamma di applicazioni ed optional.

ES_ Los modelos básicos están disponibles en tres tamaños diferentes y pueden utilizarse de manera neutral o equipados con una amplia gama de aplicaciones y opcionales.

FR_ Les modèles de base sont disponibles en trois tailles différentes et peuvent être utilisés neutres ou équipés d'un large éventail d'applications et d'optionales.



Table sizes

ART. COOK 160
cm 160x80x(h)82

MODEL C:
No plates holding compartment.

ART. COOK 210
cm 210x80x(h)82

MODEL C:
No plates holding compartment.

ART. COOK 250
cm 250x80x(h)82

MODEL C:
No plates holding compartment.

Basic models are available in two different sizes and can be used neutral or equipped with a wide range of appliances and options.

IT_ I modelli base sono disponibili in due differenti misure e possono essere utilizzati neutri oppure equipaggiati con una vasta gamma di applicazioni ed optional.

ES_ Los modelos básicos están disponibles en dos tamaños diferentes y pueden utilizarse de manera neutral o equipados con una amplia gama de aplicaciones y opcionales.

FR_ Les modèles de base sont disponibles en deux tailles différentes et peuvent être utilisés neutres ou équipés d'un large éventail d'applications et d'optionals.



Table sizes

ART. SELF SERVICE 210

cm 210x80x(h)82

MODEL A:

Two plates holding compartments: cm 120x30x(h)17

MODEL B:

One plates holding compartment: cm 120x30x(h)17

ART. SELF SERVICE 250

cm 250x80x(h)82

MODEL A:

Two plates holding compartments: cm 132x30x(h)17

MODEL B:

One plates holding compartment: cm 132x30x(h)17

These tables can be equipped with one or two plates holder.

IT_ Questi tavoli possono essere equipaggiati di uno o due porta piatti.

ES_ Estas mesas pueden equiparse con uno o dos soportes de platos.

FR_ Ces tables peuvent être équipées d'un ou deux porte-assiettes.

MODEL A - TWO PLATES HOLDERS

MODELLO A 210

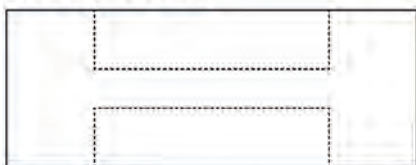

MODELLO A 250

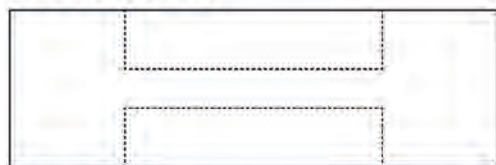

EN_ This table can be customized only in colours. Appliances can not be apply.

IT_ Questo tavolo può essere personalizzato solo nei colori. Le applicazioni non possono essere inserite.

ES_ Esta mesa puede ser personalizada solamente en los colores. Las aplicaciones no pueden ser insertadas.

FR_ Ce table peut être personnalisé uniquement en couleurs. Les applications ne peuvent pas être appliquées.

MODEL B - ONE PLATES HOLDER

MODELLO B 210



MODELLO B 250



EN_ This table can be customized in colours and appliances.

IT_ Questo tavolo può essere personalizzato in colori e applicazioni.

ES_ Esta mesa puede ser personalizada en colores y aplicaciones.

FR_ Ce table peut être personnalisé en couleurs et en applications.

MODEL C - NO PLATES HOLDER

MODELLO C 210

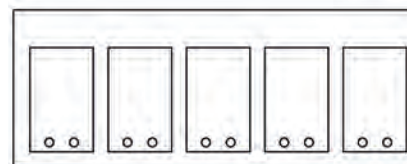

MODELLO C 250

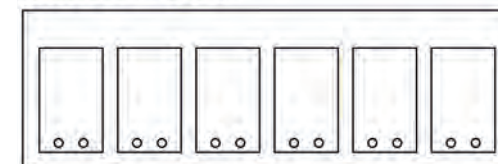

EN_ This table can be customized in colours and appliances.

IT_ Questo tavolo può essere personalizzato in colori e applicazioni.

ES_ Esta mesa puede ser personalizada en colores y aplicaciones.

FR_ Ce table peut être personnalisé en couleurs et en applications.

Cooking appliances

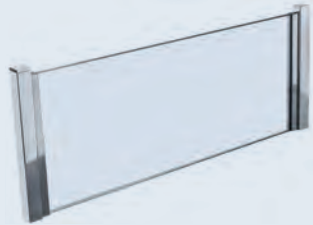

X5	
cm 60 h cm 24	
EN_	Protection in tempered glass and 18/10 stainless steel.
IT_	Protezione in vetro temperato e acciaio inossidabile 18/10.
ES_	Protección en vidrio templado y acero inoxidable 18/10.
FR_	Protection en verre trempé et acier inoxydable 18/10.

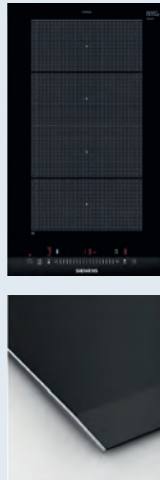

DOM25	
cm 30,2x52 220 - 240V 1N ~ / 3,7kW	
EN_	Induction hob - 3 cooking zones. Glass-ceramic with blunted front side and lateral profiles in stainless steel
IT_	Piano cottura ad induzione - 3 postazioni di cottura. Vetroceramica con frontale smussato e profili in acciaio inossidabile.
ES_	Placa de inducción - 3 zonas de cocción. Vitrocerámica con frente romo y perfiles laterales an acero inoxidable.
FR_	Plaque à induction - 3 zones de cuisson. Vitrocéramique avec façade biseautées et profils latéraux en acier inoxydable.



DOM15	
cm 38x52 230V ~ 1P+N 50/60Hz	
EN_	Induction glass-ceramic hob - 1 cooking zone.
IT_	Piano cottura ad induzione in vetroceramica - 1 postazione di cottura.
ES_	Placa de inducción en vitrocerámica - 1 zona de cocción.
FR_	Plaque à induction en vitrocéramique - 1 zone de cuisson.

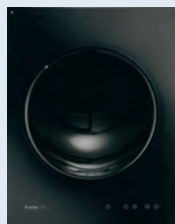

DOM12	
cm 40x52 220-230V 50/60Hz	
EN_	Induction glass-ceramic wok hob.
IT_	Piano cottura ad induzione wok in vetro ceramica.
ES_	Encimera wok de inducción en vitrocerámica.
FR_	Table de cuisson wok à induction en vitrocéramique.

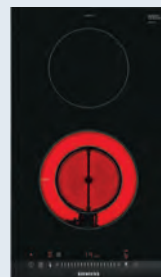

DOM26	
cm 30,2x52 220-240V / 50/60Hz	
EN_	Glass-ceramic hob - 2 cooking zones.
IT_	Piano cottura in vetroceramica - 2 postazioni di cottura.
ES_	Placa en vitrocerámica - 2 zonas de cocción.
FR_	Plaque en vitrocéramique - 2 zones de cuisson.



DOM33	
cm 39x52 220 - 240V / 1,9kW	
EN_	TeppanYaki plate.
IT_	Piastra TeppanYaki.
ES_	Placa TeppanYaki.
FR_	Plaque TeppanYaki.

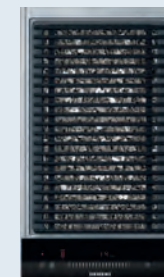

DOM5	
cm 39,2x52 220 - 240V / 3,4kW	
EN_	Lava stone grill plate.
IT_	Piastra grill a pietra lavica.
ES_	Placa grill de piedra de lava.
FR_	Plaque grill en pierre de lave.

Table equipped with induction glass-ceramic hob.

cm 30X52 - 220 - 240V 1N /3,7kW.



IT_ Tavolo equipaggiato con piano cottura ad induzione in vitroceramica.

ES_ Mesa equipada de placa de inducción en vitrocerámica.

FR_ Table équipé de plaque à induction en vitrocéramique.



ART. COOK 210/W5/DOM25

colours available	matt finish	W1	B1	C2
	climb finish	W5	B2	C1
	ultra matt finish	W2	B6	

Some examples



ART. SELF SERVICE 250/MODELB/B2/DOM25/DOM25/X5/X5

Table equipped with two induction glass-ceramic hobs and protection in tempered glass and 18/10-AISI 304 stainless steel.

cm 30X52 - 220 - 240V 1N /3,7kW.



- IT_* Tavolo equipaggiato con due piani cottura ad induzione in vitroceramica e protezione in vetro temperato e acciaio inossidabile 18/10-AISI 304.
- ES_* Mesa equipada de dos placas de inducción en vitrocerámica y protección en vidrio templado y acero inoxidable 18/10-AISI 304.
- FR_* Table équipé avec deux plaques à induction en vitrocéramique et protection en verre trempé et acier inoxydable 18/10-AISI 304.

Appliances: see page 47.

colours available	matt finish	W1	B1	C2
	climb finish	W5	B2	C1
	ultra matt finish	W2	B6	

neo



This collection of restaurant tables is the protagonist of our “gastronomy”. The innovative materials used in the production make them strong, durable and easy to clean, without neglecting design and aesthetics. The valuable finishes also make them elegant and modern.

IT_ Questa collezione di tavoli da ristorante è la protagonista della nostra “gastronomia”. I materiali innovativi utilizzati nella produzione li rendono forti, duraturi e di facile manutenzione, senza trascurare design ed estetica. Le finiture di pregio li rendono inoltre eleganti e moderni.

ES_ Esta colección de mesas de restaurante es la protagonista de nuestra “gastronomía”. Los materiales innovadores utilizados en su producción, los hacen fuertes, duraderos y de fácil mantenimiento, sin descuidar el design y la estética. Los preciosos acabados los hacen, además, elegantes y modernos.

FR_ Cette collection de tables de restaurant est le protagoniste de notre “gastronomie”. Les matériaux innovants utilisés dans la production les rendent solides, durables et faciles à nettoyer, sans pour autant négliger le design et l’esthétique. Les finitions raffinées les rendent également élégantes et modernes.



Tables are available in three different sizes.

IT_ I tavoli sono disponibili in tre differenti misure.

ES_ Mesas estan disponible en tres tamaños diferentes.

FR_ Les tables sont disponible en trois tailles différentes.



ART. NEO 90/W2
cm 90x80x(h)80



ART. NEO 160/W2
cm 160x80x(h)80

Table sizes

ART. NEO 90
cm 90x80x(h)80

ART. NEO 160
cm 160x80x(h)80

ART. NEO 210
cm 210x80x(h)80

**Simple and elegant restaurant tables,
embellished with mirror finish
18/10-AISI 304 stainless steel details.**

- IT_* Tavoli da ristorante semplici ed eleganti, impreziositi da dettagli in acciaio inossidabile 18/10-AISI 304 lucidato a specchio.
- ES_* Mesas de restaurante sencillas y elegantes, adornadas con detalles des acero inoxidable 18/10-AISI 304 acabado espejo.
- FR_* Tables de restaurant simples et élégantes, agrémentées de détails en acier inoxydable 18/10-AISI 304 poli miroir.



ART. NEO 210/W2
cm 210x80x(h)80

colours available	matt finish	W1	B1	C2
	climb finish	W5	B2	C1
	ultra matt finish	W2	B6	

star





STAR is a simple and essential collection of tables for hotel lobbies, which with its elegance is suitable for all receptions and waiting areas, making them cozy and comfortable.

IT_ STAR è una collezione di tavoli per le hall d'albergo semplice ed essenziale, che con la sua eleganza si adatta a tutti gli ambienti di accoglienza e attesa, rendendoli ospitali e confortevoli.

ES_ STAR es una colección de mesas simple y esencial para los vestibulos de hoteles, que con su elegancia se conforma a todos los entornos de recepción y espera, volviendolos acogedores y confortables.

FR_ STAR est une collection simples et essentiels de tables pour les halls d'hôtel qui, avec son élégance, convient à toutes les zones de réception et d'attente, les rendant ainsi accueillantes et confortables.

Basic model available in three different sizes.

IT_ Modello base disponibile in tre differenti misure.

ES_ Modelo básico disponible en tres tamaños diferentes.

FR_ Modèle de base disponible en trois tailles différentes.



ART. STAR 90/W2
cm 90x80x(h)26

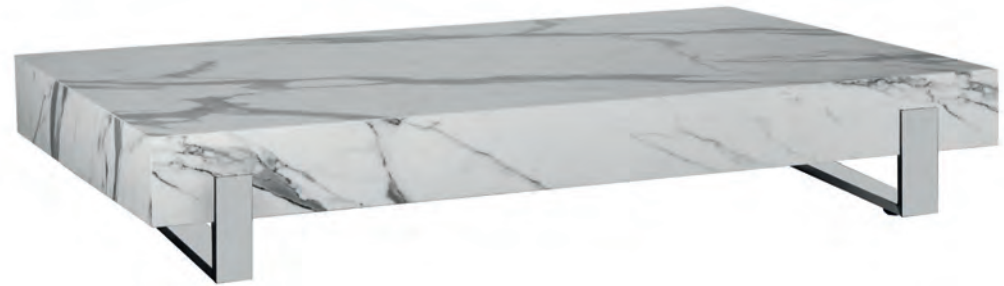

ART. STAR 160/W2
cm 160x80x(h)26

Table sizes

ART. STAR 90
cm 90x80x(h)26

ART. STAR 160
cm 160x80x(h)26

ART. STAR 210
cm 210x80x(h)26

Linear and essential lobby tables, embellished with the structure in 18/10-AISI 304 stainless steel, which adapts to any environment making it cozy and comfortable.

- IT_* Tavoli da hall lineari ed essenziali, impreziositi dalla struttura in acciaio inossidabile 18/10-AISI 304, che si adattano ad ogni ambiente rendendolo ospitale e confortevole.
- ES_* Mesas para los vestibulos de hoteles lineales y esenciales, embellecidas por la estructura en acero inoxidable 18/10-AISI 304, que se adapta a cualquier entorno haciéndolo acogedor y confortable.
- FR_* Tables pour les halls d'hôtel linéaires et essentielles, embellies par la structure en acier inoxydable 18/10-AISI 304 poli miroir, qui s'adapte à n'importe quel environnement, le rendant hospitalier et confortable.

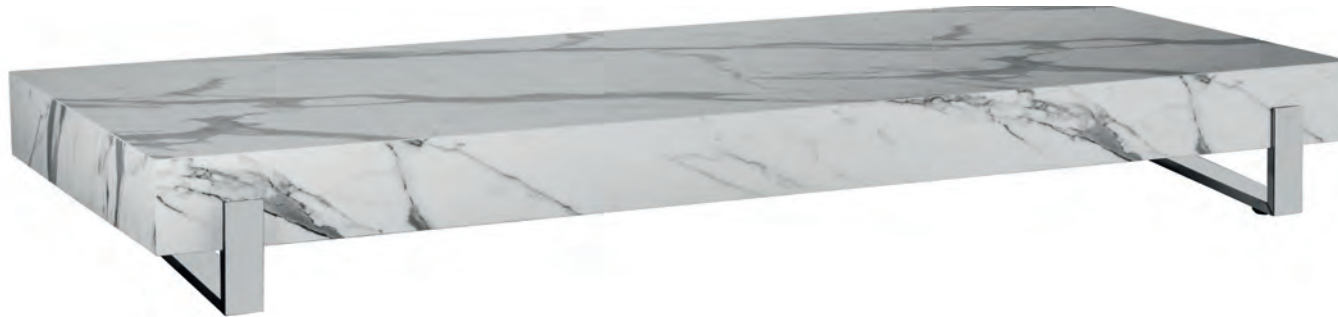

ART. STAR 210/W2
cm 210x80x(h)26

colours available	matt finish	W1	B1	C2
	climb finish	W5	B2	C1
	ultra matt finish	W2	B6	

moon



MOON is a simple and essential collection of tables for hotel lobbies, which with its elegance is suitable for all receptions and waiting areas, making them cozy and comfortable.

IT_ MOON è una collezione di tavoli per le hall d'albergo semplice ed essenziale, che con la sua eleganza si adatta a tutti gli ambienti di accoglienza e attesa, rendendoli ospitali e confortevoli.

ES_ MOON es una colección de mesas simple y esencial para los vestíbulos de hoteles, que con su elegancia se conforma a todos los entornos de recepción y espera, volviéndolos acogedores y confortables.

FR_ MOON est une collection simples et essentiels pour les halls d'hôtel qui, avec son élégance, convient à toutes les zones de réception et d'attente, les rendant ainsi accueillantes et confortables.



Basic model available in three different sizes.

IT_ Modello base disponibile in tre differenti misure.

ES_ Modelo básico disponible en tres tamaños diferentes.

FR_ Modèle de base disponible en trois tailles différentes.



ART. MOON 90/B2
cm 90x80x(h)23



ART. MOON 160/B2
cm 160x80x(h)23

Table sizes

ART. MOON 90
cm 90x80x(h)23

ART. MOON 160
cm 160x80x(h)23

ART. MOON 210
cm 210x80x(h)23

Linear and essential lobby tables which adapts to any environment making it cozy and comfortable.

IT_ Tavoli da hall lineari ed essenziali che si adatto ad ogni ambiente rendendolo ospitale e confortevole.

ES_ Mesas para los vestibulos de hoteles lineales y esenciales que se adaptan a cualquier entorno haciéndolo acogedor y confortable.

FR_ Tables pour les halls d'hôtel linéaires et essentielles qui s'adapte à n'importe quel environnement, le rendant hospitalier et confortable.

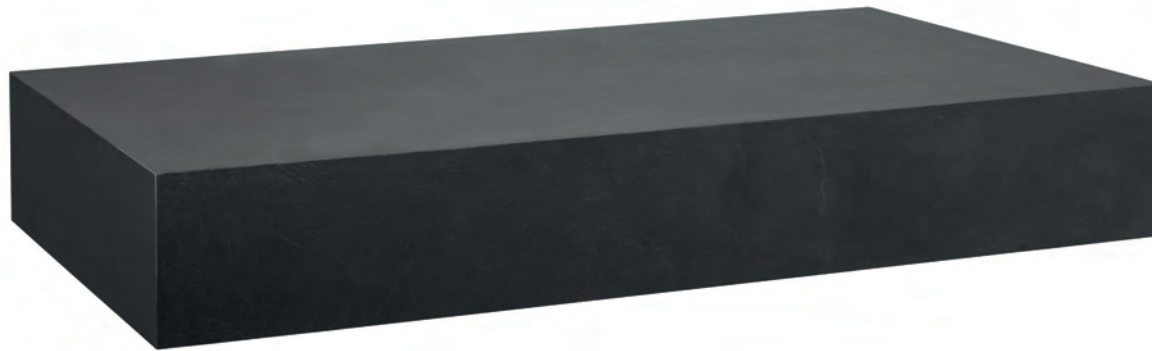

ART. MOON 210/B2
cm 210x80x(h)23

colours available	matt finish	W1	B1	C2
	climb finish	W5	B2	C1
	ultra matt finish	W2	B6	

modular tables

A family of compatible and modular tables, available fixed or with adjustable height. They can be placed side by side to offer endless combinations of presentation and at the same time allow a space of minimum encumbrance when not in use thanks to the possibility of being stacked. Perfect both as a buffet table and as a high cocktail table or a table where you can eat standing up. Thanks to their flexibility and multi-functionality, these design tables represent a valid solution for hotels, restaurants and bars.

IT_ Una famiglia di tavoli compatibili e modulari, disponibili fissi oppure ad altezza regolabile. Possono essere accostati per offrire infinite combinazioni di presentazione e allo stesso tempo consentire uno spazio di ingombro minimo quando non in uso grazie alla possibilità di essere impilati. Perfetti sia come tavoli da buffet, sia come tavoli alti da cocktail o tavoli mangia in piedi. Grazie alla loro flessibilità e multifunzionalità, questi tavoli di design rappresentano una valida soluzione per gli hotel, i ristoranti e i bar.

ES_ Una familia de mesas compatibles y modulares, disponibles fijas o con altura regulable. Se pueden colocar lado a lado para ofrecer infinitas combinaciones de presentación y, al mismo tiempo, permiten un espacio de volumen mínimo cuando no están en uso gracias a la posibilidad de apilarse. Perfecto tanto como una mesa de buffet y como una mesa alta de cóctel o una mesa donde se puede comer de pie. Gracias a su flexibilidad y multifuncionalidad, estas mesas de diseño representan una solución válida para hoteles, restaurantes y bares.

FR_ Une famille de tables compatibles et modulaires, disponibles en version fixe ou à hauteur réglable. Ils peuvent être placés côte à côte pour offrir une infinité de combinaisons de présentation tout en ménageant un espace d'encombrement minimal lorsqu'ils ne sont pas utilisés, grâce à la possibilité d'empilement. Parfait à la fois comme table de buffet et comme table de cocktail haute ou comme table où vous pouvez manger debout. Grâce à leur flexibilité et leur multifonctionnalité, ces tables de design représentent une solution valable pour les hôtels, les restaurants et les bars.



Available in white and black climb finish

IT_ Disponibili in bianco e nero con finitura climb.

ES_ Disponible en blanco y negro con acabado climb.

FR_ Disponible en noir et blanc avec finition climb.

CLIMB

finishe



W5
white climb

B2
black ardesia

Customization of all tables on request.
See page 68 and contact our sales office .

High pressure laminate

IT_ Laminato ad alta pressione

ES_ Laminado de alta presión

FR_ Stratifié haute pression

EN_ Revolution and innovation in an excellent material thanks to its functional and aesthetic potentialities. Anti-scratch, waterproof, resistant to oils, steam and water. Unalterable up to 60°, anti bacterial and long lasting.

IT_ Rivoluzione ed innovazione in un materiale eccellente per le sue potenzialità funzionali ed estetiche. Anti-graffio, impermeabile, resiste ad oli, vapore ed acqua. Inalterabile fino a 60°, anti batterico e duraturo.

ES_ Revolución e innovación en un material excelente por sus potencialidades funcionales y estéticas. Anti-rasguños, impermeable, resistente a aceites, vapor y agua. Inalterable hasta 60°, antibacteriano y de larga duración.

FR_ Révolution et innovation dans un excellent matériau pour ses potentialités fonctionnelles et esthétiques. Anti-rayures, imperméable, résistant aux huiles, à la vapeur et à l'eau. Inaltérable jusqu'à 60°, anti bactérien et durable.

Stainless steel 18/10-AISI 304 brushed

IT_ Acciaio inossidabile 18/10-AISI 304 - Satinato

ES_ Acero inoxidable 18/10-AISI 304 - Satinado

FR_ Acier inoxydable 18/10-AISI 304 - Satiné

EN_ Rigorous in its shapes for a linear and functional aesthetic. 100% recyclable, no maintenance, corrosion resistance and mechanical features are some of the connotations that make it an essential material.

IT_ Rigoroso nelle sue forme per un'estetica lineare e funzionale. 100% riciclabile, assenza di manutenzione, resistenza alla corrosione e caratteristiche meccaniche di rilievo sono alcune delle connotazioni che lo rendono un prodotto imprescindibile.

ES_ Riguroso en sus formas para una estética lineal y funcional. 100% reciclable, sin mantenimiento, resistencia a la corrosión y características mecánicas significativas son algunas de las connotaciones que lo convierten en un producto esencial.

FR_ Rigoureux dans ses formes pour une esthétique linéaire et fonctionnelle. 100% recyclable, pas d'entretien, résistance à la corrosion et caractéristiques mécaniques sont des connotations qui en font un produit essentiel.



1
Made of a 12 mm high pressure laminate panel.

IT_ Realizzati con un pannello di laminato ad alta pressione da 12 mm.

ES_ Fabricado con un panel laminado de alta presión de 12 mm.

FR_ Fabriqués en stratifié haute pression de 12 mm.

2
Structure made of 18/10-AISI 304 brushed stainless steel.

IT_ Struttura realizzata in acciaio inossidabile 18/10-AISI 304 satinato.

ES_ Estructura realizada en acero inoxidable 18/10-AISI 304 satinado.

FR_ Structure en acier inoxydable 18/10-AISI 304 satiné.

3
Equipped with 4 pivoting, non-marking wheels with brakes, to facilitate service maneuvers and storage.

IT_ Muniti di 4 ruote pivotanti, antitraccia e dotate di freno, per facilitare la manovre di servizio e stoccaggio.

ES_ Equipado con 4 ruedas pivotantes, que no dejan marcas, con frenos para facilitar las operaciones de servicio y almacenamiento.

FR_ Equipé de 4 roues pivotantes, non marquantes avec freins, pour faciliter les manœuvres d'entretien et stockage.



smart



Set of two stackable tables, available in two colours - Black Ardesia and White Climb.

IT_ Set di due tavoli impilabili, disponibili in due varianti colore - Black Ardesia e White Climb.

ES_ Juego de dos mesas apilables, disponibles en dos colores - Black Ardesia y White Climb.

FR_ Ensemble de deux tables empilables, disponibles en deux couleurs - Black Ardesia et White Climb.

Basic model available in two different sizes.

IT_ Modello base disponibile in due differenti misure.

ES_ Modelo básico disponible en dos tamaños diferentes.

FR_ Modèle de base disponible en deux tailles différentes.



ART. SMART 160/W5
cm 160x80x(h)78



ART. SMART 206/W5
cm 206x80x(h)88

Optional: Protection - see page 68.

Optional protection



ART. X1

EN_ Neutral polycarbonate protection.

IT_ Protezione neutra in policarbonato.

ES_ Protección neutra de policarbonato.

FR_ Protection neutre en polycarbonate.



ART. X2

EN_ Neutral tempered glass protection and plates holder.

IT_ Protezione e appoggio per piatti neutro in vetro temperato.

ES_ Protección y soporte de platos neutro de vidrio templado.

FR_ Protection et porte-assiettes neutre en verre trempé.



ART. SMART 206B/W5/X1
cm 206x80x(h)88+55

Table with shelf. cm 206x80x(h)88.

IT_ Tavolo con ripiano.
ES_ Mesa con estante.
FR_ Table avec étagère.



ART. SMART 206B/W5
cm 206x80x(h)88

colours available

climb finish

W5

B2

Optional

Neutral polycarbonate protection.

IT_ Protezione neutra in policarbonato.

ES_ Protección neutra de policarbonato.

FR_ Protection neutre en polycarbonate.

domino



Set of three stackable tables with telescopic legs, available in two colours - Black Ardesia and White Climb.

IT_ Set di tre tavoli impilabili con gambe telescopiche, disponibili in due varianti colore - Black Ardesia e White Climb.

ES_ Juego de tres mesas apilables con patas telescópicas, disponibles en dos colores - Black Ardesia y White Climb.

FR_ Ensemble de trois tables empilables avec pieds télescopiques, disponibles en deux couleurs - Black Ardesia et White Climb.



ART. DOMINO 206/W5
cm 206x80x(h)92



ART. DOMINO 160/W5
cm 160x80x(h)80/92

ART. DOMINO 100/W5
cm 100x80X(h)70/80/92

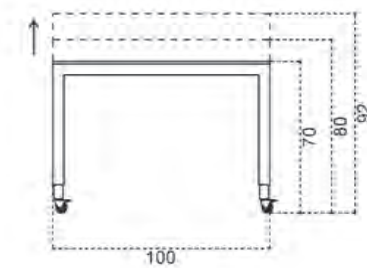
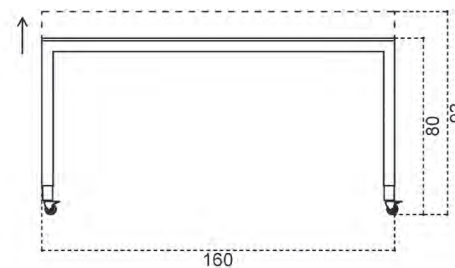
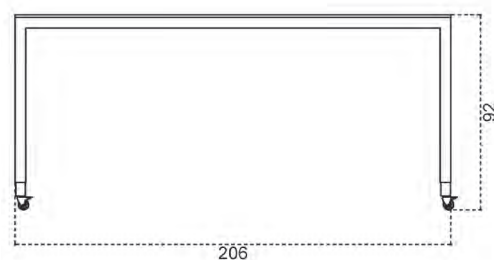
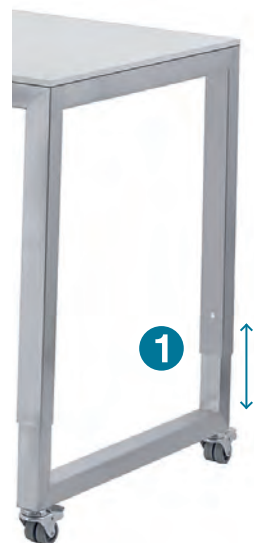

1
Telescopic legs to get up to three heights.

IT_ Gambe telescopiche per ottenere fino a tre altezze.

ES_ Patas telescópicas para conseguir hasta tres alturas.

FR_ Pieds télescopiques pour atteindre trois hauteurs.

Basic model available in three different sizes.

IT_ Modello base disponibile in tre differenti misure.

ES_ Modelo básico disponible en tres tamaños diferentes.

FR_ Modèle de base disponible en trois tailles différentes.

colours available

climb finish

 W5

 B2



ART. DOMINO 100/W5
cm 100x80x(h)70/80/92



ART. DOMINO 160/W5
cm 160x80x(h)80/92



ART. DOMINO 206/W5
cm 206x80x(h)92

ART. 7124

Service trolley complete with two plastic baskets.

IT_ Carrello di servizio con due cestini in plastica.
ES_ Carrito de servicio con dos cestas en plastico.
FR_ Chariot de service avec deux panier en plastique.



ART. 7123

Service trolley.

IT_ Carrello di servizio.
ES_ Carrito de servicio.
FR_ Chariot de service.



top	size	cm 100x50x(h)87+8
	max cap.	kg 60
shelves	size	cm 100x50
	max cap.	kg 60

counters

Buffet counters, the most effective solution for storing and displaying a wide variety of foods in hotels, restaurants and catering. Designed on wheels, they can be easily dislocated and used for breakfast, lunch and dinner buffets. Available in warm, refrigerated and neutral models, they are ideal not only to keep alterable foods at temperature, but also non-perishable foodstuffs.

IT_ Banchi buffet ad isola, la soluzione più efficace per conservare ed esporre una grande varietà di alimenti in strutture alberghiere, ristoranti e catering. Ideati su ruote possono essere facilmente dislocati ed utilizzati durante i servizi buffet di colazione, pranzo e cena. Disponibili in modelli caldi, refrigerati e neutri, sono ideali non solo per mantenere a temperatura i cibi alterabili, ma anche generi alimentari non deperibili.

ES_ Mostradores de buffet, la solución más efectiva para almacenar y mostrar una amplia variedad de alimentos en hoteles, restaurantes y catering. Diseñados sobre ruedas, pueden disolverse fácilmente y usarse para los bufets de desayuno, almuerzo y cena. Disponibles en modelos cálidos, refrigerados y neutros, son ideales no solo para mantener los alimentos alterables a temperatura, sino también los alimentos no perecederos.

FR_ Comptoirs de buffet la solution la plus efficace pour stocker et afficher une grande variété de plats dans les hôtels, les restaurants et les catering. Conçus sur roues, ils peuvent être facilement déplacés et utilisés pour les buffets de petit-déjeuner, déjeuner et dîner. Disponibles en modèles chauds, réfrigérés et neutres, elles sont idéales non seulement pour conserver les aliments interchangeable à la température, mais également pour les aliments non périssables.





Tetris



1
Made of poplar wood covered with 9/10 high pressure laminate.

2
Available with worktop in 18/10-AISI 304 stainless steel.

3
Equipped with 6 pivoting, non-marking wheels with brakes, to facilitate service maneuvers and storage.

IT_ Realizzati in legno di pioppo rivestito da laminato ad alta pressione da 9/10.

IT_ Disponibile con piano di lavoro in acciaio inossidabile 18/10-AISI 304.

IT_ Muniti di 6 ruote pivotanti, antiraccia e dotate di freno, per facilitare le manovre di servizio e stoccaggio.

Idea



ES_ Hecho en madera de álamo revestido de laminado de alta presión 9/10.

ES_ Disponible con llano de trabajo en acero inoxidable 18/10-AISI 304.

ES_ Equipado con 6 ruedas rotatorias, antihuellas y con frenos, para facilitar las maniobras de servicio y almacenamiento.

FR_ Fabriqués en bois de peuplier recouvert de stratifié haute pression de 9/10.

FR_ Disponible avec plan de travail en acier inoxydable 18/10-AISI 304.

FR_ Equipé de 6 roues pivotantes, non marquantes avec freins, pour faciliter les manœuvres d'entretien et stockage.

MATT

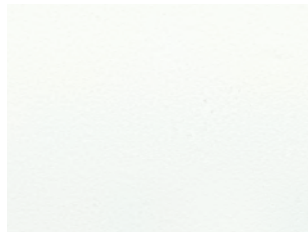

W1
white ice

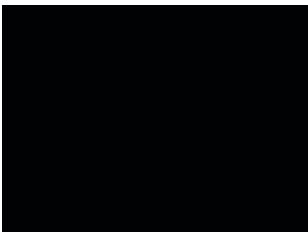

B1
black



C2
walkprint

CLIMB

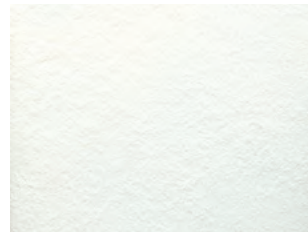

W5
white climb

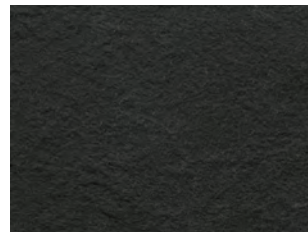

B2
black ardesia



C1
greige

MOD ULTRA MATT

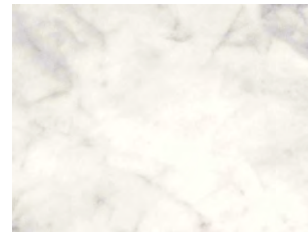

W2
statuario

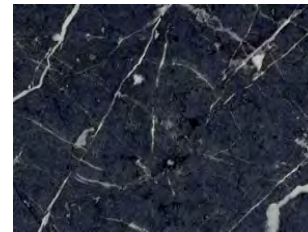

B6
alicante

WOOD



R1
ash



Q1
cherry rose

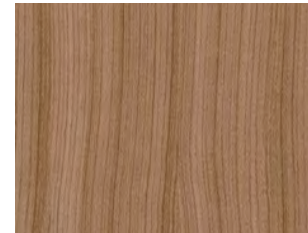

A1
noce marbella

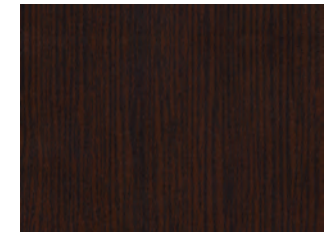

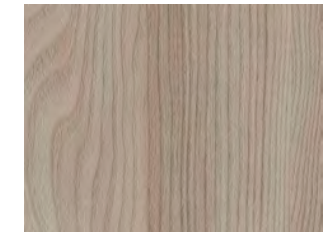

E1
wengé congo







U1
pearl elm





Customization of all trolleys on request. See pages 78-81 and contact our sales office .





Appliances available:

COLD MAINTENANCE APPLIANCES	Appliances	Code	Description				Technical info	TETRIS 34	TETRIS 35	IDEA 51	IDEA 52
		COL54	<i>EN_</i> Refrigerated glass-ceramic top. Adjustable temperature from -5 to +15°C. Remote control.	<i>IT_</i> Piano refrigerato in vetroceramica. Temperatura regolabile da -5 a +15°C. Comando remoto.	<i>ES_</i> Placa de vidrio ceramica refrigerada. Temperatura regulable de -5 a +15°C. Comando a distancia.	<i>FR_</i> Plateau réfrigéré en vitrocéramique. Température réglable de -5 à +15°C.	2 GN 1/1 cm 53x66 170W - 230V - 50/60Hz	●		●	
		COL55	<i>EN_</i> Refrigerated 18/10-AISI 304 stainless steel basin. Remote control.	<i>IT_</i> Vasca refrigerata in acciaio inossidabile 18/10-AISI 304. Comando remoto.	<i>ES_</i> Cubeta refrigerada de acero inoxidable 18/10-AISI 304. Comando a distancia.	<i>FR_</i> Bac réfrigérée en acier inoxydable 18/10-AISI 304. Commande à distance.	3 GN 1/1 cm 106x62 depth cm 3 350W - 220V - 50Hz	●		●	
		COL56	<i>EN_</i> Refrigerated 18/10-AISI 304 stainless steel basin. Adjustable temperature from -5 to +8°C. Remote control.	<i>IT_</i> Vasca refrigerata in acciaio inossidabile 18/10-AISI 304. Temperatura regolabile da -5 a +8°C. Comando remoto.	<i>ES_</i> Cubeta refrigerada de acero inoxidable 18/10-AISI 304. Temperatura regulable de -5 a +8°C. Comando a distancia.	<i>FR_</i> Bac réfrigérée en acier inoxydable 18/10-AISI 304. Température réglable de -5 à +8°C.	6 GN 1/1 cm 205x63 depth cm 3 256W - 220V - 50Hz	●		●	

Appliances	Code	Description				Technical info	TETRIS 34	TETRIS 35	IDEA 51	IDEA 52
	IND50	EN_ Induction glass-ceramic top heat-retaining unit. Remote control.	IT_ Unità di mantenimento del calore ad induzione in vetroceramica. Comando remoto.	ES_ Unidad de mantenimiento de calor por inducción de vitrocerámica. Comando a distancia.	FR_ Unité de chauffage par induction en vitrocéramique. Commande à distance.	2x cm 39x39 2x cm 52x32 230V - 3,2kW	●		●	
	IND51	EN_ Induction glass-ceramic top heat-retaining unit. Remote control.	IT_ Unità di mantenimento del calore ad induzione in vetroceramica. Comando remoto.	ES_ Unidad de mantenimiento de calor por inducción de vitrocerámica. Comando a distancia.	FR_ Unité de chauffage par induction en vitrocéramique. Commande à distance.	cm 80x40 230V - 1,5kW	●		●	
	HOT52	EN_ 18/10-AISI 304 stainless steel heating plate. Adjustable temperature from +30 to +90°C. Remote control.	IT_ Piano caldo in acciaio inossidabile 18/10-AISI 304. Temperatura regolabile da +30 a +90°C. Comando remoto.	ES_ Placa calentadora en acero inoxidable 18/10-AISI 304. Temperatura regulable de +30 a +90°C. Comando a distancia.	FR_ Plateau chauffante en acier inoxydable 18/10-AISI 304. Température réglable de +30 à +90°C. Commande à distance.	2 GN 1/1 cm 70x58x(H)7 800W - 230V - 50/60Hz	●		●	
	HOT53	EN_ 18/10-AISI 304 stainless steel heating plate. Adjustable temperature from +30 to +90°C. Remote control.	IT_ Piano caldo in acciaio inossidabile 18/10-AISI 304. Temperatura regolabile da +30 a +90°C. Comando remoto.	ES_ Placa calentadora en acero inoxidable 18/10-AISI 304. Temperatura regulable de +30 a +90°C. Comando a distancia.	FR_ Plateau chauffante en acier inoxydable 18/10-AISI 304. Température réglable de +30 à +90°C. Commande à distance.	6 GN 1/1 cm 194x52x(H)7 1600W - 230V - 50/60Hz	●		●	
	HOT55	EN_ Three stainless steel chafing dish. GN 1/1, depth mm 65. Glass lid with stainless steel frame and soft closure. Complete with electric plate with regulator.	IT_ Tre chafing dish in acciaio inossidabile. GN 1/1, profondità mm 65. Coperchio in vetro con cornice in acciaio inossidabile e chiusura ammortizzata. Completa di piastra elettrica con regolatore.	ES_ Tres chafing dish en acero inoxidable. GN 1/1, profundidad mm 65. Tapa de vidrio con marco de acero inoxidable y cierre armonizado. Completo con placa eléctrica con regulador.	FR_ Trois chafing dish en acier inoxydable. GN 1/1, profondeur mm 65. Couvercle en verre avec cadre en acier inoxydable et fermeture harmonisé. Complet avec plaque électrique avec régulateur.	cm 58x45x(h)25 400W - 230V		●		●

Optionals available:

OPTIONALS	Optionals	Code	Description				Technical info	TETRIS 34	TETRIS 35	IDEA 51	IDEA 52
		R200	<i>EN_</i> Perimeter barrier.	<i>IT_</i> Barriera perimetrale.	<i>ES_</i> Barrera perimetral.	<i>FR_</i> Barrière de périmètre.	cm 200	●		●	
		S	<i>EN_</i> Reclining plates stand.	<i>IT_</i> Scorripiatti reclinabile.	<i>ES_</i> Pasaplatos reclinable.	<i>FR_</i> Porte-assiettes rabattable.	cm 205x25	●	●	●	●
		ANC1	<i>EN_</i> Anchor hook.	<i>IT_</i> Gancio di ancoraggio.	<i>ES_</i> Gancho anclado.	<i>FR_</i> Crochet d'ancorage.	Ø cm 9 h cm 4,5	●	●	●	●
		ANG1	<i>EN_</i> Edge protection.	<i>IT_</i> Paraspigoli.	<i>ES_</i> Protección para bordes.	<i>FR_</i> Protection de bord.	Aluminum	●	●	●	●
		Y8	<i>EN_</i> Protective work surface panels that turn the buffet counter into a useful support surface.	<i>IT_</i> Assi per protezione piano di lavoro che trasformano il banco buffet in un utile piano d'appoggio.	<i>ES_</i> Tablas para la protección del plano de trabajo que vuelven el banco buffet en un llano de apoyo.	<i>FR_</i> Panneaux de protection des surfaces de travail qui transforment le comptoir buffet en une surface de support utile.	Two panels cm 100x63//each	●	●	●	●

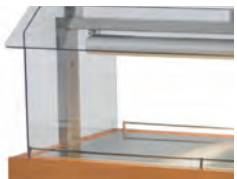
Optionals	Code	Description				Technical info	TETRIS 34	TETRIS 35	IDEA 51	IDEA 52
	X1	<i>EN_</i> Neutral polycarbonate protection.	<i>IT_</i> Protezione neutra in polycarbonato.	<i>ES_</i> Protección neutra de polycarbonato.	<i>FR_</i> Protection neutre en polycarbonate.	cm 205 h cm 55	●	●	●	●
	Y1	<i>EN_</i> Polycarbonate protection with LED lighting.	<i>IT_</i> Protezione in polycarbonato con illuminazione LED.	<i>ES_</i> Protección de polycarbonato con iluminación LED.	<i>FR_</i> Protection en polycarbonate avec éclairage LED.		●	●	●	●
	Z1	<i>EN_</i> Polycarbonate protection with heating lamp. Only to be combined with appliance Art. HOT53. See page 79.	<i>IT_</i> Protezione in polycarbonato con lampada riscaldante. Abbinabile solo all'applicazione Art. HOT 53. Vedi pagina 79.	<i>ES_</i> Protección de polycarbonato con lámpara de calentamiento. Para ser combinado solo con l'applicacion Art. HOT53. Ver página 79.	<i>FR_</i> Protection en polycarbonate avec lampe chauffante. Combinable seulement avec l'application Art. HOT53. Voir page 79.		●	●	●	●
	X2	<i>EN_</i> Protection and support for plates, neutral, in tempered glass.	<i>IT_</i> Protezione e appoggio per piatti, neutro, in vetro temperato.	<i>ES_</i> Protección y soporte para platos, neutros, de vidrio templado.	<i>FR_</i> Protection et support pour vaisselles, neutre, en verre trempé.	cm 205 h cm 50	●	●	●	●
	Y2	<i>EN_</i> Protection and support for plates, with LED light, in tempered glass.	<i>IT_</i> Protezione e appoggio per piatti, con luce LED, in vetro temperato.	<i>ES_</i> Protección y soporte para placas, con luz LED, de vidrio templado.	<i>FR_</i> Protection et support pour vaisselles, avec éclairage LED, en verre trempé.		●	●	●	●
	Y6	<i>EN_</i> Polycarbonate side protection for both sides. Only to be combined with Art. X1-Y1-Z1.	<i>IT_</i> Protezione laterale in polycarbonato per ambo i lati. Compatibile solo con Art. X1-Y1-Z1.	<i>ES_</i> Protección lateral de polycarbonato para ambos lados. Para ser combinado solo con los Art. X1-Y1-Z1.	<i>FR_</i> Protection latérale en polycarbonate des deux côtés. Combinable seulement avec les Art. X1-Y1-Z1.	cm 55,5 h cm 50	●	●	●	●



ART. TETRIS 34

Neutral counter.

IT_ Banco buffet neutro.

ES_ Isla buffet neutra.

FR_ Comptoir buffet neutre.

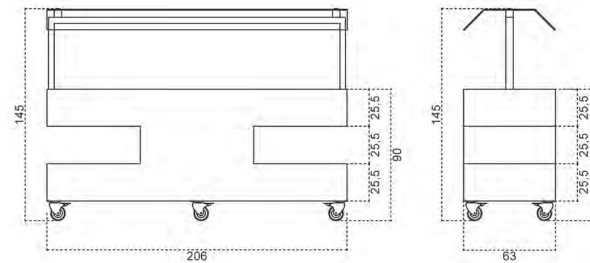
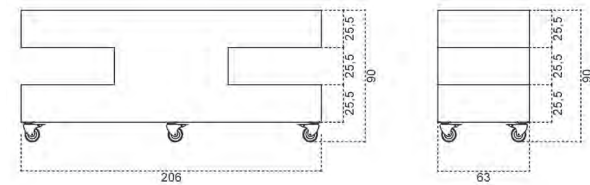

ART. TETRIS 36

colours available	matt finish	W1	B1	C2
	climb finish	W5	B2	C1
	ultra matt finish	W2	B6	
	wood finish	R1	Q1	A1
		E1	U1	

Neutral counter with 18/10-AISI 304 stainless steel top surface.

IT_ Banco buffet neutro con piano in acciaio inossidabile 18/10-AISI 304.

ES_ Isla buffet neutra con llano de acero inoxidable 18/10-AISI 304.

FR_ Comptoir buffet neutre avec plan de travail en acier inoxydable 18/10-AISI 304.



ART. TETRIS 35

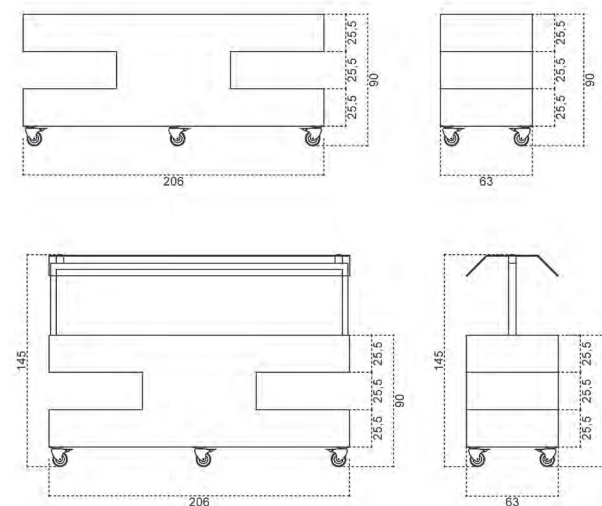

colours available	matt finish	W1	B1	C2
	climb finish	W5	B2	C1
	ultra matt finish	W2	B6	
	wood finish	R1	Q1	A1
		E1	U1	

Some examples

For each collection we will offer some examples of customization that can be applied to counters.

IT_ Per ogni collezione proporremo alcuni esempi di personalizzazione che possono essere applicati ai banchi buffet.

ES_ Para cada colección ofreceremos algunos ejemplos de personalización que se pueden aplicar a las islas buffet.

FR_ Pour chaque collection, nous vous proposons quelques exemples de personnalisation qui pouvant être appliqués aux comptoirs.

***EN_* Deagostini Inox offers its customers a personalized design service.**

Contact our sales office and request a customized proposal regarding products, finishes colours and technical equipment.

The technical office is at our disposal to combine our range of proposals based on your needs!

IT_ La Deagostini Inox offre ai propri clienti un servizio di progettazione personalizzato. Contatta il nostro ufficio vendite e richiedi una proposta su misura in merito a prodotti, finiture, colori e attrezzature tecniche.

L'ufficio tecnico è a tua disposizione per combinare la nostra gamma di proposte in base alle tue esigenze!

ES_ Deagostini Inox ofrece a sus clientes un servicio de design personalizado.

Póngase en contacto con nuestra oficina de ventas y solicite una propuesta personalizada en cuanto a productos, acabados, colores y equipos técnicos.

La oficina técnica está a su disposición para combinar nuestra gama de propuestas según sus necesidades!

FR_ Deagostini Inox propose à ses clients un service de design sur mesure.

Contactez notre bureau des ventes et demandez une proposition personnalisée concernant les produits, les finitions, les couleurs et les équipements techniques.

Le bureau technique est à votre disposition pour combiner notre gamme de propositions en fonction de vos besoins!

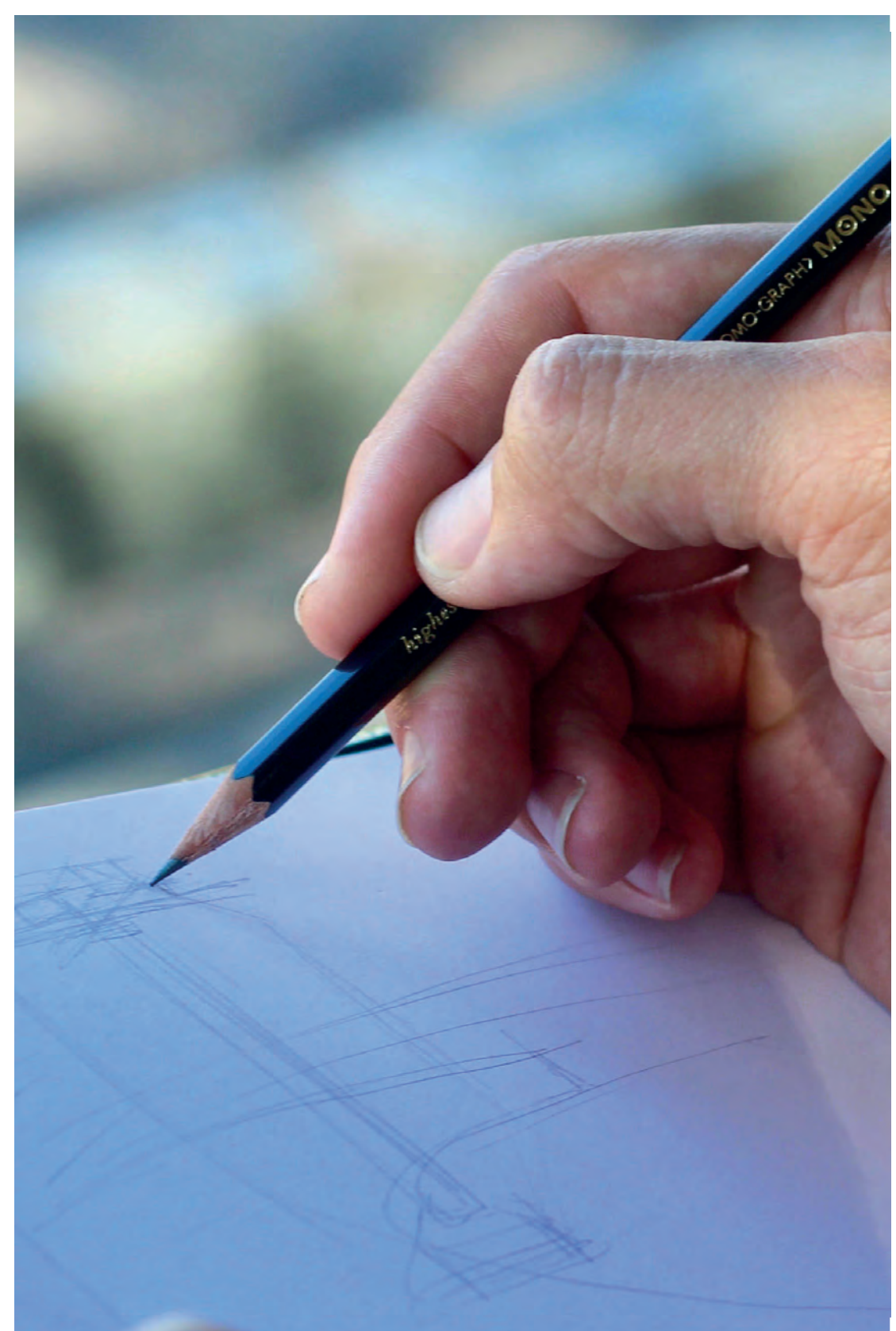

Some examples



ART. TETRIS 35/B1/HOT55/ANG1

Counter equipped with three 18/10-AISI 304 stainless steel chafing dish. GN 1/1, depth mm 65. Glass lid with stainless steel frame and soft closure. Complete with electric plate with regulator.



- IT_* Banco buffet equipaggiato con tre chafing dish in acciaio inossidabile 18/10-AISI 304. GN 1/1, profondità mm 65. Coperchio in vetro con cornice in acciaio inossidabile e chiusura ammortizzata. Completa di piastra elettrica con regolatore.
- ES_* Isla buffet equipada de chafing dish en acero inoxidable 18/10-AISI 304. GN 1/1, profundidad mm 65. Tapa de vidrio con marco de acero inoxidable y cierre armonizado. Completo con placa eléctrica con regulador.
- FR_* Comptoir buffet équipé de trois chafing dish en acier inoxydable 18/10-AISI 304. GN 1/1, profondeur mm 65. Couvercle en verre avec cadre en acier inoxydable et fermeture harmonisée. Complet avec plaque électrique avec régulateur.

colours available	matt finish	W1	B1	C2
	climb finish	W5	B2	C1
	ultra matt finish	W2	B6	
	wood finish	R1	Q1	A1
		E1	U1	

Optional

Edge protection.

IT_ Paraspigoli.

ES_ Protección para bordes.

FR_ Protection de bord.

Counter equipped with 18/10-AISI 304 stainless steel heating plate.

Adjustable temperature from +30 to +90°C.
6 GN 1/1 - cm 194x52 - 200W - 230V - 50/60Hz.



ART. TETRIS 34/Q1/HOT53/R200/Z1

- IT_* Banco buffet equipaggiato con piano caldo in acciaio inossidabile 18/10-AISI 304.
ES_ Isla buffet equipada de placa calentadora de acero inoxidable 18/10-AISI 304.
FR_ Comptoir buffet équipé de plateau chauffante en acier inoxydable 18/10-AISI 304.

colours available	matt finish	W1	B1	C2
	climb finish	W5	B2	C1
	ultra matt finish	W2	B6	
	wood finish	R1	Q1	A1
E1		U1		

Optionals

Polycarbonate protection with heating lamp.

IT_ Protezione in policarbonato con lampada riscaldante.

ES_ Protección de policarbonato con lámpara de calentamiento.

FR_ Protection en polycarbonate avec lampe chauffante.

Perimeter barrier.

IT_ Barriera perimetrale.

ES_ Barrera perimetral.

FR_ Barrière de périmètre.

Some examples



ART. TETRIS 34/C2/IND51/X1

Counter equipped with induction glass-ceramic table top heat retaining unit.



IT_ Banco buffet equipaggiato con unità di mantenimento del calore ad induzione in vetroceramica.

ES_ Isla buffet equipada con unidad de mantenimiento de calor para inducción de vidrio-cerámica

FR_ Comptoir buffet équipé de unité de chauffage par induction en vitrocéramique.

colours available	matt finish	W1	B1	C2
	climb finish	W5	B2	C1
	ultra matt finish	W2	B6	
	wood finish	R1	Q1	A1
		E1	U1	

Optional

Neutral polycarbonate protection.

IT_ Protezione neutra in polycarbonato.

ES_ Protección de polycarbonato.

FR_ Protection neutre en polycarbonate.

Counter equipped with refrigerated 18/10-AISI 304 stainless steel basin.

Adjustable temperature from -5 to +8°C.

6 GN 1/1 - cm 205x63 - depth cm 3 - 256W - 220V - 50Hz.



ART. TETRIS 34/B1/COL56

IT_ Banco buffet equipaggiato con vasca refrigerata in acciaio inossidabile 18/10-AISI 304.

ES_ Isla buffet equipada de cubeta refrigerada de acero inoxidable 18/10-AISI 304.

FR_ Comptoir buffet équipé de bac réfrigérée en acier inoxydable 18/10-AISI 304.

colours available	matt finish	W1	B1	C2
	climb finish	W5	B2	C1
	ultra matt finish	W2	B6	
	wood finish	R1	Q1	A1
E1		U1		

Some examples



ART. TETRIS 34/B1/COL56/S/X1/ANG1

Counter equipped with refrigerated 18/10-AISI 304 stainless steel basin.

Adjustable temperature from -5 to +8°C.

6 GN 1/1 - cm 205x63 - depth cm 3 - 256W - 220V - 50Hz.



IT_ Banco buffet equipaggiato con vasca refrigerata in acciaio inossidabile 18/10-AISI 304.

ES_ Isla buffet equipada de cubeta refrigerada de acero inoxidable 18/10-AISI 304.

FR_ Comptoir buffet équipé de bac réfrigérée en acier inoxydable 18/10-AISI 304.

colours available	matt finish	W1	B1	C2
	climb finish	W5	B2	C1
	ultra matt finish	W2	B6	
	wood finish	R1	Q1	A1
		E1	U1	

Optionals

Reclining plates stand.

IT_ Scorripiatti reclinabile.

ES_ Pasaplatos reclinable.

FR_ Porte-assiettes rabattable.

Neutral polycarbonate protection.

IT_ Protezione neutra in policarbonato.

ES_ Protección de policarbonato.

FR_ Protection neutre en polycarbonate.

Edge protection.

IT_ Paraspigoli.

ES_ Protección para bordes.

FR_ Protection de bord.

Counter equipped with refrigerated 18/10-AISI 304 stainless steel basin.

Adjustable temperature from -5 to +8°C.
GN 6/1 - cm 205x63 - 256W - 220V - 50Hz.



- IT_* Banco buffet equipaggiato con vasca refrigerata in acciaio inossidabile 18/10-AISI 304.
ES_ Isla buffet equipada de placa calentadora de acero inoxidable 18/10-AISI 304.
FR_ Comptoir buffet équipé de bac réfrigérée en acier inoxydable 18/10-AISI 304.



ART. TETRIS 34/Q1/COL56/X1

colours available	matt finish	W1	B1	C2
	climb finish	W5	B2	C1
	ultra matt finish	W2	B6	
	wood finish	R1	Q1	A1
E1		U1		

Optional

Neutral polycarbonate protection.

IT_ Protezione neutra in policarbonato.

ES_ Protección de policarbonato.

FR_ Protection neutre en polycarbonate.

Some examples



ART. TETRIS 34/C2/COL54/COL54

Counter equipped with two refrigerated glass-ceramic top.

Adjustable temperature from -5 to $+15^{\circ}\text{C}$.
2X2 GN 1/1-170W - 50/60Hz.



IT_ Banco buffet equipaggiato con due piani refrigerati in vetroceramica.
ES_ Isla buffet equipada de dos placas refrigeradas de vidrio ceramica.
FR_ Comptoir buffet équipé de deux plateaux réfrigéré en vitrocéramique.

colours available	matt finish	W1	B1	C2
	climb finish	W5	B2	C1
	ultra matt finish	W2	B6	
	wood finish	R1	Q1	A1
		E1	U1	

Counter equipped with two refrigerated glass-ceramic top.
Adjustable temperature from -5 to +15°C.



ART. TETRIS 34/C2/COL54/COL54/X1



IT_ Banco buffet equipaggiato con due piani refrigerati in vetroceramica.
ES_ Isla buffet equipado de tapas refrigerada de vidrio ceramica.
FR_ Comptoir buffet équipé de deux plateaux réfrigéré en vitrocéramique.

colours available	matt finish	W1	B1	C2
	climb finish	W5	B2	C1
	ultra matt finish	W2	B6	
	wood finish	R1	Q1	A1
		E1	U1	

Optional

Neutral polycarbonate protection.

IT_ Protezione neutra in polycarbonato.

ES_ Protección de polycarbonato.

FR_ Protection neutre en polycarbonate.



TETRIS / HIGH PRESSURE LAMINATE - STAINLESS STEEL



ART. IDEA 51

Neutral counter.

IT_ Banco buffet neutro.

ES_ Isla buffet neutra.

FR_ Banco buffet neutro.

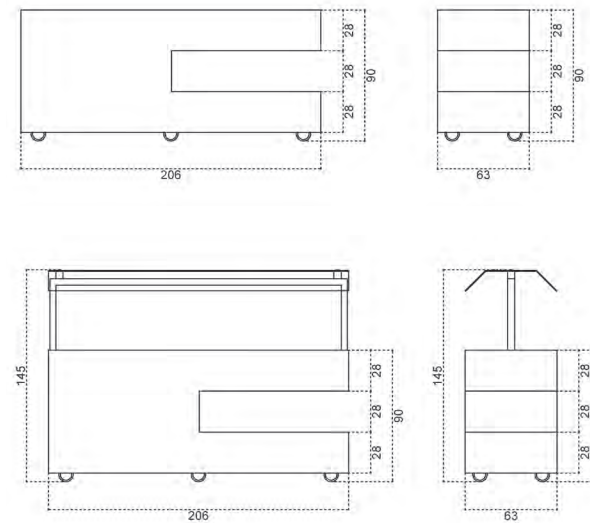

colours available	matt finish	W1	B1	C2
	climb finish	W5	B2	C1
	ultra matt finish	W2	B6	
	wood finish	R1	Q1	A1
		E1	U1	

Neutral counter with 18/10-AISI 304 stainless steel top surface.

IT_ Banco buffet neutro con piano in acciaio inossidabile 18/10-AISI 304.

ES_ Isla buffet neutra con llano de acero inoxidable 18/10-AISI 304.

FR_ Comptoir buffet neutre avec étagère en acier inoxydable 18/10-AISI 304.



ART. IDEA 52

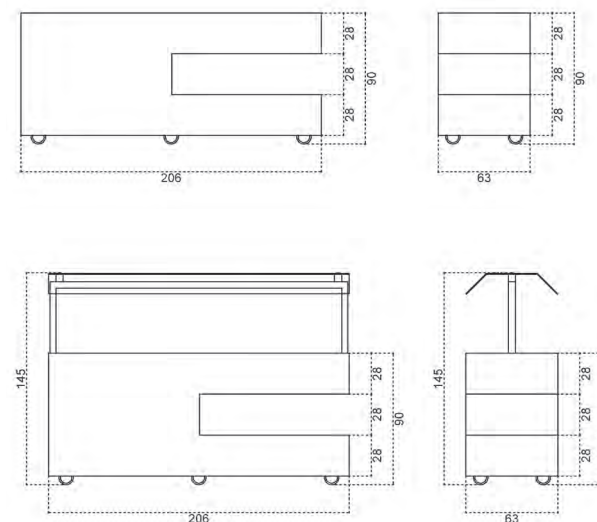

colours available	matt finish	W1	B1	C2
	climb finish	W5	B2	C1
	ultra matt finish	W2	B6	
	wood finish	R1	Q1	A1
		E1	U1	

Counter equipped with three 18/10-AISI 304 stainless steel chafing dish. GN 1/1, depth mm 65. Glass lid with stainless steel frame and soft closure. Complete with electric plate with regulator.



ART. IDEA 52/W1/HOT55



- IT_* Banco buffet equipaggiato con tre chafing dish in acciaio inossidabile 18/10-AISI 304. GN 1/1, profondità mm 65. Coperchio in vetro con cornice in acciaio inossidabile e chiusura ammortizzata. Completa di piastra elettrica con regolatore.
- ES_* Isla buffet equipada de chafing dish en acero inoxidable 18/10-AISI 304. GN 1/1, profundidad mm 65. Tapa de vidrio con marco de acero inoxidable y cierre armonizado. Completo con placa eléctrica con regulador.
- FR_* Comptoir buffet équipé de trois chafing dish en acier inoxydable 18/10-AISI 304. GN 1/1, profondeur mm 65. Couvercle en verre avec cadre en acier inoxydable et fermeture harmonisé. Complet avec plaque électrique avec régulateur.

colours available	matt finish	W1	B1	C2
	climb finish	W5	B2	C1
	ultra matt finish	W2	B6	
	wood finish	R1	Q1	A1
		E1	U1	

Some examples



ART. IDEA 51/E1/COL56

Counter equipped with refrigerated 18/10-AISI 304 stainless steel basin.

Adjustable temperature from -5 to +8°C.

6 GN 1/1 - cm 205X63 - depth cm 3 - 256W - 220V - 50Hz.



IT_ Banco buffet equipaggiato con vasca refrigerata in acciaio inossidabile 18/10-AISI 304.

ES_ Isla buffet equipada de placa calentadora de acero inoxidable 18/10-AISI 304.

FR_ Comptoir buffet équipé de bac réfrigérée en acier inoxydable 18/10-AISI 304.

colours available	matt finish	W1	B1	C2
	climb finish	W5	B2	C1
	ultra matt finish	W2	B6	
	wood finish	R1	Q1	A1
		E1	U1	

Optional



EN_ Protective work surface panels that turn the buffet counter into a useful support surface.

IT_ Pannelli per protezione piano di lavoro che trasformano il banco buffet in un utile piano d'appoggio.

ES_ Tablas para la protección del llano de trabajo que vuelven el banco buffet en un llano de apoyo.

FR_ Panneaux de protection des surfaces de travail qui transforment le comptoir buffet en une surface de support utile.

Some examples



ART. IDEA 51/R1/HOT53/Z1

Counter equipped with 18/10-AISI 304 stainless steel heating plate.

Adjustable temperature from +30 to +90°C.

6 GN 1/1 - cm 194x52 - 200W - 230V - 50/60Hz.



IT_ Banco buffet equipaggiato con piano caldo in acciaio inossidabile 18/10-AISI 304.

ES_ Isla buffet equipada de placa calentadora de acero inoxidable 18/10-AISI 304.

FR_ Comptoir buffet équipé de plateau chauffante en acier inoxydable 18/10-AISI 304.

colours available				
matt finish	<table border="0"> <tr> <td> W1</td> <td> B1</td> <td> C2</td> </tr> </table>	W1	B1	C2
W1	B1	C2		
climb finish	<table border="0"> <tr> <td> W5</td> <td> B2</td> <td> C1</td> </tr> </table>	W5	B2	C1
W5	B2	C1		
ultra matt finish	<table border="0"> <tr> <td> W2</td> <td> B6</td> <td></td> </tr> </table>	W2	B6	
W2	B6			
wood finish	<table border="0"> <tr> <td> R1</td> <td> Q1</td> <td> A1</td> </tr> </table>	R1	Q1	A1
	R1	Q1	A1	
<table border="0"> <tr> <td> E1</td> <td> U1</td> <td></td> </tr> </table>	E1	U1		
E1	U1			

Optional

Polycarbonate protection with heating lamp.

IT_ Protezione in policarbonato con lampada riscaldante.

ES_ Protección de policarbonato con lámpara de calentamiento.

FR_ Protection en polycarbonate avec lampe chauffante.



ART. IDEA 51/R1/HOT53
COMBINED WITH ART. 6007/C1/N

Counter equipped with 18/10-AISI 304 stainless steel heating plate.

Adjustable temperature from +30 to +90°C.

6 GN 1/1 - cm 194x52 - 200W - 230V - 50/60Hz.



IT_ Banco buffet equipaggiato con piano caldo in acciaio inossidabile 18/10-AISI 304.

ES_ Isla buffet equipada de placa calentadora de acero inoxidable 18/10-AISI 304.

FR_ Comptoir buffet équipé de plateau chauffante en acier inoxydable 18/10-AISI 304.

One column dishes elevator. Available heated (H) or neutral (N). Provided with lid and schuko socket.

IT_ Alzapiatti ad una colonna. Disponibile riscaldato (H) o neutro (N). Completo di coperchio e presa schuko.

ES_ Dispensador de platos con una columna. Disponible con calefacción (H) o neutro (N). Provisto de tapa y enchufe schuko.

FR_ Monte assiettes à une colonne. Disponible chauffé (H) ou neutre (N). Pourvu du couvercle et prise schuko.

top	size	cm 55x55x(h)88+22
	max cap.	kg 50
dish elevator	size	Ø cm 21/29
	max cap.	55 dishes max
	power	230V - 400W - Adjustable thermostat

colours available	matt finish	W1	B1	C2
	climb finish	W5	B2	C1
	ultra matt finish	W2	B6	
	wood finish	R1	Q1	A1
E1		U1		



IDEA / HIGH PRESSURE LAMINATE - STAINLESS STEEL



Plates holder: cm 90x30x(h)26

1
Made in poplar wood, covered with 9/10 high pressure laminate panel.

IT_ Realizzata in legno di pioppo rivestito da un pannello di laminato ad alta pressione da 9/10.

ES_ Hecha en madera de álamo, cubierto por un panel de laminado alta presión 9/10.

FR_ Réalisée en bois de peuplier recouvert d'un panneau stratifié 9/10 haute pression.

2
Details and appliances are made in brushed 18/10-AISI 304 stainless steel.

IT_ I dettagli e le applicazioni sono in acciaio inossidabile 18/10-AISI 304 satinato.

ES_ Los detalles están hecho de acero inoxidable 18/10-AISI 304 satinado.

FR_ Les détails et les applications sont en acier inoxydable 18/10-AISI304 satiné.

3
Large table top and support for sliding plates.

IT_ Ampio piano d'appoggio e scorrimento dei piatti.

ES_ Amplio llano de apoyo y deslizar por platos.

FR_ Large plan d'appui et support pour les assiettes.

4
6 non-marking, pivoting wheels with parking brake.

IT_ 6 ruote antitraccia, pivotanti e dotate di freno di stazionamento.

ES_ 6 ruedas antihuellas, rotatorias, con bloqueo incluido.

FR_ 6 roues pivotantes non marquantes équipées d'un frein de stationnement.

5
Four plate-holding compartments carved into the structure.

IT_ Quattro vani porta piatti ricavati nella struttura.

ES_ Quatro repisas portaplatos empotrados en la estructura.

FR_ Quatre compartiments porte-assiettes gravés dans la structure.

Optionals



X2

EN_ Neutral tempered glass protection.

IT_ Protezione neutra in vetro temperato.

ES_ Protección neutra de vidrio templado.

FR_ Protection neutre en verre trempé.



Y2

EN_ Tempered glass protection with LED lighting.

IT_ Protezione in vetro temperato con illuminazione LED.

ES_ Protección de vidrio templado con iluminación LED.

FR_ Protection en verre trempé avec éclairage LED.



X1

EN_ Neutral polycarbonate protection.

IT_ Protezione neutra in polycarbonato.

ES_ Protección neutra de polycarbonato.

FR_ Protection neutre en polycarbonate.



Y1

EN_ Polycarbonate protection with LED lighting.

IT_ Protezione in polycarbonato con illuminazione LED.

ES_ Protección de polycarbonato con iluminación LED.

FR_ Protection en polycarbonate avec éclairage LED.



Z1

EN_ Polycarbonate protection with heating lamp.

IT_ Protezione in polycarbonato con lampada riscaldante.

ES_ Protección de polycarbonato con lampara de calentamiento.

FR_ Protection en polycarbonate avec lampe chauffante.

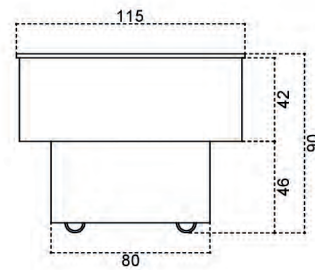
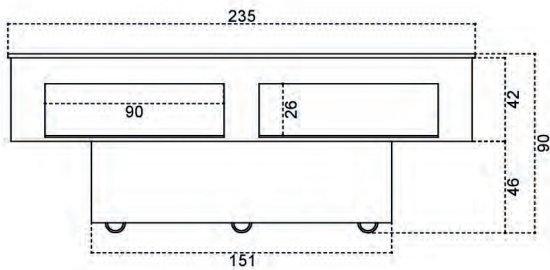
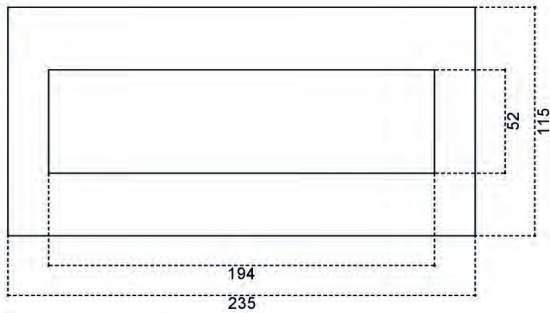

ART. DOUBLE HOT/R1/B1/X1

Optional

Neutral polycarbonate protection.

IT_ Protezione neutra in polycarbonato.

ES_ Protección neutra de polycarbonato.

FR_ Protection neutre en polycarbonate.

**Counter equipped with refrigerated
18/10-AISI 304 stainless steel basin.**
GN 6/1 - cm 205x63 - depth cm 3 - 256W - 220V - 50Hz.
Adjustable temperature from -5 to +8°C.



- IT_* Banco buffet equipaggiato con piano refrigerato in acciaio inossidabile 18/10-AISI 304.
ES_ Isla buffet equipada de cubeta refrigerada de acero inoxidable 18/10-AISI 304.
FR_ Comptoir buffet équipé de bac réfrigérée en acier inoxydable 18/10-AISI 304.

ART. DOUBLE COLD/R1/B1



colours available	matt finish	W1	B1	C2
	climb finish	W5	B2	C1
	ultra matt finish	W2	B6	
	wood finish	R1	Q1	A1
		E1	U1	

dishes elevators



The dishes elevators represent the completion of the buffet counters and live cooking stations collections. Perfectly compatible, they can be made in all the colours and finishes available, so as to define a complete, refined and functional service.

IT_ I mobili alzapiatti rappresentano il completamento delle collezioni di banchi buffet e live cooking stations. Perfettamente compatibili, possono essere realizzati in tutte le varianti colore e finiture disponibili, così da definire un servizio completo, raffinato e funzionale.

ES_ Los levantaplatos representan la finalización de las colecciones de mesa de buffet y live cooking stations. Perfectamente compatibles, se pueden fabricar en todos los colores y acabados disponibles, a fin de definir un servicio completo, refinado y funcional.

FR_ Les porte vaisselle représentent l'achèvement des collections du comptoir buffet et live cooking stations. Parfaitement compatibles, ils peuvent être réalisés dans toutes les couleurs et finitions disponibles, afin de définir un service complet, raffiné et fonctionnel.



NEUTRAL

HEATED



ART. 6007

ART. 6008

**One column dishes elevator.
Available heated (H) or neutral (N).
Provided with lid and schuko socket.**

IT_ Alzapiatti ad una colonna. Disponibile riscaldato (H) o neutro (N).
Completo di coperchio e presa schuko.

ES_ Dispensador de platos con una columna. Disponible con calefacción (H) o neutro (N). Provisto de tapa y enchufe schuko.

FR_ Monte assiettes à une colonne. Disponible chauffé (H) ou neutre (N).
Pourvu du couvercle et prise schuko.

colours available	matt finish	W1	B1	C2
	climb finish	W5	B2	C1
	ultra matt finish	W2	B6	
	wood finish	R1	Q1	A1
		E1	U1	

top	size	cm 55x55x(h)88+22
	max cap.	kg 50
dish elevator	size	Ø cm 21/29
	max cap.	55 dishes max
	power	230V - 400W Adjustable thermostat



NEUTRAL

ART. 6011

HEATED

ART. 6010



Two column dishes elevator. Available heated (H) or neutral (N). Provided with lid and schuko socket.

IT_ Alzapiatti a due colonne. Disponibile riscaldato (H) o neutro (N).
Completo di coperchio e presa schuko.

ES_ Dispensador de platos con dos columnas. Disponible con calefacción (H) o neutro (N). Provisto de tapa y enchufe schuko.

FR_ Monte assiettes à deux colonnes. Disponible chauffé (H) ou neutre (N).
Pourvu du couvercle et prise schuko.

colours available	
matt finish	 W1 B1 C2
climb finish	 W5 B2 C1
ultra matt finish	 W2 B6
wood finish	 R1 Q1 A1
	 E1 U1

top	size	cm 100x55x(h)88+22
	max cap.	kg 100
dish elevator	size	Ø cm 21/29
	max cap.	110 dishes max
	power	230V - 400W Adjustable thermostat

live cooking & cocktail stations

Live cooking stations represent the turning point of Deagostini Inox. From 2005 until today we have been committed to improve each day a product characterized by innovative materials, latest generation technology, functional and modern design.

All manufactured in our factories, they are the guarantee of a Made in Italy product, that embodies all our professionalism and experience, from 1946 to today.

IT_ Le live cooking stations rappresentano il prodotto di svolta della Deagostini Inox. Dal 2005 ad oggi ci siamo impegnati a migliorare ogni giorno un prodotto caratterizzato da materiali innovativi, tecnologia di ultima generazione e design funzionale e moderno. Tutte realizzate presso i nostri stabilimenti, sono la garanzia di un prodotto Made in Italy, che racchiude tutta la nostra professionalità ed esperienza, dal 1946 ad oggi.

ES_ Las live cooking stations representan el punto de inflexión de Deagostini Inox. Desde 2005 hasta hoy nos hemos comprometido a mejorar cada día un producto caracterizado por materiales innovadores, tecnología de última generación y diseño funcional y moderno. Todos hechos en nuestras fábricas, son la garantía de un producto Made in Italy, que encarna todo nuestro profesionalismo y experiencia, desde 1946 hasta hoy.

FR_ Les live cooking stations représentent le point tournant de Deagostini Inox. De 2005 à aujourd'hui, nous nous sommes engagés à améliorer chaque jour un produit caractérisé par des matériaux innovants, une technologie de dernière génération et un design fonctionnel et moderne. Tous fabriqués dans nos usines, ils sont la garantie d'un produit Made in Italy, qui incarne tout notre professionnalisme et notre expérience de 1946 à nos jours.





Functionality, Technology and Design.

High pressure laminate - Layered

IT_ Laminato ad alta pressione - Multistrato
ES_ Laminado de alta presión - Multicapas
FR_ Stratifié haute pression - Multicouche

EN_ Revolution and innovation in an excellent material thanks to its functional and aesthetic potentialities. Anti-scratch, waterproof, resistant to oils, steam and water. Unalterable up to 60°, anti bacterial and long lasting.

IT_ Rivoluzione ed innovazione in un materiale eccellente per le sue potenzialità funzionali ed estetiche. Anti-graffio, impermeabile, resiste ad oli, vapore ed acqua. Inalterabile fino a 60°, anti batterico e duraturo.

ES_ Revolución e innovación en un material excelente por sus potencialidades funcionales y estéticas. Anti-rasguños, impermeable, resistente a aceites, vapor y agua. Inalterable hasta 60°, antibacteriano y de larga duración.

FR_ Révolution et innovation dans un excellent matériau pour ses potentialités fonctionnelles et esthétiques. Anti-rayures, imperméable, résistant aux huiles, à la vapeur et à l'eau. Inaltérable jusqu'à 60°, anti bactérien et durable.

Stainless steel 18/10-AISI 304 - Mirror finis

IT_ Acciaio inossidabile 18/10-AISI 304 - Lucidato a specchio
ES_ Acero inoxidable 18/10-AISI 304 - Acabado espejo
FR_ Acier inoxydable 18/10-AISI 304 - Poli miroir

EN_ 100% recyclable, long lasting and with mechanical features that ensure needless maintenance, corrosion resistance and sustainability. Bright finishes make details accurate and distinctive.

IT_ 100% riciclabile, duraturo e con caratteristiche meccaniche di rilievo che garantiscono assenza di manutenzione, resistenza alla corrosione e durevolezza. Le finiture brillanti rendono i dettagli accurati e distintivi.

ES_ 100% reciclable, duradero y con características mecánicas de relevancia que aseguran el mantenimiento, la resistencia a la corrosión y la durabilidad. Los brillantes acabados hacen que los detalles sean precisos y distintivos.

FR_ 100% recyclable, durable et avec des caractéristiques mécaniques de relief qui assurent aucun entretien, résistance à la corrosion et durabilité. Les finitions brillantes rendent les détails précis et distinctifs.

Made of poplar wood covered with 9/10 high pressure laminate.

IT_ Realizzati in legno di pioppo rivestito da laminato ad alta pressione da 9/10.

ES_ Hechos en madera de álamo revestido de laminado de alta presión de 9/10.

FR_ Fabriqués en bois de peuplier recouvert de stratifié haute pression de 9/10.

Worktop surface made with a 12 mm high pressure laminate panel.

IT_ Piano di lavoro realizzato con un pannello di laminato ad alta pressione da 12 mm.

ES_ Encimera realizada con un panel laminado de alta presión de 12 mm.

FR_ Plan de travail fabriqué avec un panneau stratifié haute pression de 12 mm.

Equipped with 6 pivoting, non-marking wheels with brakes, to facilitate service maneuvers and storage.

IT_ Muniti di 6 ruote pivotanti, antiraccia e dotate di freno, per facilitare la manovre di servizio e stoccaggio.

ES_ Equipados con 6 ruedas rotatorias, antihuellas y con frenos, para facilitar las maniobras de servicio y almacenamiento.

FR_ Equipé de 6 roues pivotantes, non marquantes avec freins, pour faciliter les manœuvres d'entretien et stockage.

Details and optionals made in 18/10-AISI 304 stainless steel.

IT_ Dettagli ed optionals realizzati in acciaio inossidabile 18/10-AISI 304.

ES_ Detalles y opcionales hecho en acero inoxidable 18/10-AISI 304.







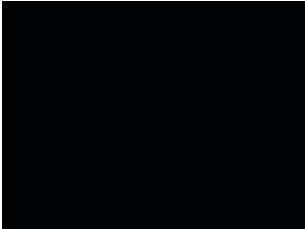

FR_ Détails et optionals réalisée en acier inoxydable 18/10-AISI 304.

Live cooking stations can be customized with a wide range of colours available.

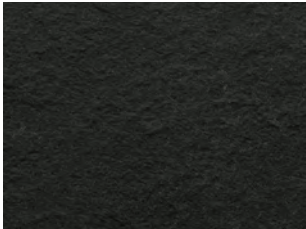
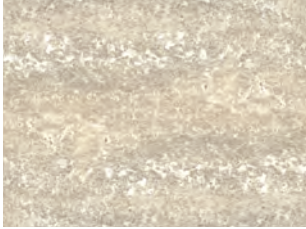

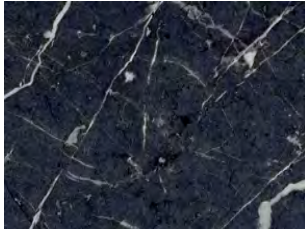
IT_ Le live cooking stations possono essere personalizzate con una vasta gamma di colori disponibili.

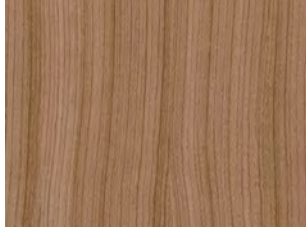
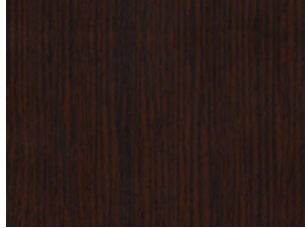
ES_ Live cooking stations se pueden personalizar con una amplia gama de colores disponibles.

FR_ Les live cooking stations peuvent être personnalisées avec une large gamme de couleurs disponibles.

finishe	MATT	CLIMB	MOD ULTRA MATT	WOOD	MIRROR
	 <p>W1 white ice</p>  <p>B1 black</p>  <p>C2 walkprint</p>	 <p>W5 white climb</p>  <p>B2 black ardesia</p>  <p>C1 greige</p>	 <p>W2 statuario</p>  <p>B6 alicante</p>	 <p>R1 ash</p>  <p>Q1 cherry rose</p>  <p>A1 noce marbella</p>	 <p>E1 wengé congo</p>  <p>U1 pearl elm</p>

Appliances

DOM15
cm 38x52 230V ~ 1P+N 50/60Hz
EN_ Induction glass-ceramic hob - 1 cooking zone.
IT_ Piano cottura ad induzione in vetro temperato - 1 postazione di cottura.
ES_ Placa de inducción de vidrio templado - 1 área de cocción.
FR_ Plaque à induction en verre trempé - 1 zone de cuisson.





DOM26
cm 30,2x52 220-240V / 50/60Hz
EN_ Glass-ceramic hob - 2 cooking zones.
IT_ Piano cottura in vitroceramica - 2 postazioni di cottura.
ES_ Placa en vitrocerámica - 2 áreas de cocción.
FR_ Plaque en vitrocéramique - 2 zones de cuisson.







DOM10
cm 29x51 230V~1P+N 50/60Hz
EN_ Induction glass-ceramic hob - 2 cooking zones.
IT_ Piano cottura ad induzione in vitroceramica - 2 postazioni di cottura.
ES_ Placa de inducción en vitrocerámica - 2 áreas de cocción.
FR_ Plaque à induction en vitrocéramique - 2 zones de cuisson.





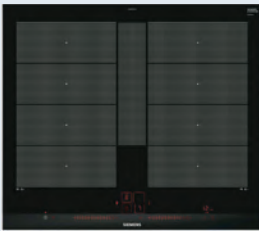

DOM25
cm 30,2x52 220 - 240V 1N ~ / 3,7kW
EN_ Induction glass-ceramic hob - 3 cooking zones.
IT_ Piano cottura ad induzione in vitroceramica - 3 postazioni di cottura.
ES_ Placa de inducción en vitrocerámica - 3 áreas de cocción.
FR_ Plaque à induction en vitrocéramique - 3 zones de cuisson.

DOM28
cm 60x52 220 - 240V 50/60Hz
EN_ Induction glass-ceramic hob - 4 cooking zones.
IT_ Piano cottura ad induzione in vitroceramica - 4 postazioni di cottura.
ES_ Placa de inducción en vitrocerámica - 4 áreas de cocción.
FR_ Plaque à induction en vitrocéramique - 4 zones de cuisson.

DOM27
cm 81x52 220 - 240V 50/60Hz
EN_ Induction glass-ceramic hob - 6 cooking zones. Integrated extractor hood with cast iron grill. Max air expulsion capacity: 690 m³/h.
IT_ Piano cottura ad induzione in vitroceramica - 6 postazioni di cottura. Unità aspirante integrata con griglia in ghisa. Capacità max espulsione aria 690 m³/h.
ES_ Placa de inducción en vitrocerámica - 6 áreas de cocción. Campana extractora integrada con rejilla de hierro fundido. Capacidad máxima de expulsión de aire: 690 m³/h.
FR_ Plaque à induction en vitrocéramique- 6 zones de cuisson. Hotte aspirante intégrée avec grille en fonte. Capacité maximale d'expulsion d'air: 690 m³/h.

EN_ Appliances subject to the composition of the furniture.

IT_ Applicazioni soggette alla composizione del mobile.

ES_ Aplicaciones sujetas a la composición del mobiliario.

FR_ Applications soumises à la composition du meuble.

Appliances



DOM33

cm 39x52
220 - 240V / 1,9kW

EN_ TeppanYaki plate.

IT_ Piastra TeppanYaki.

ES_ Placa TeppanYaki.

FR_ Plaque TeppanYaki.

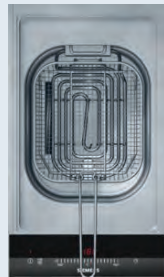

DOM7

cm 30x52 - It 6
220 - 240V / 2,5kW

EN_ Fryer.

IT_ Friggitrice.

ES_ Freidora.

FR_ Friteuse.

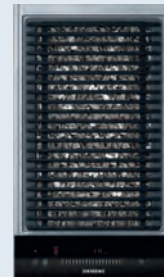

DOM5

cm 39,2x52
220 - 240V / 3,4kW

EN_ Lava stone grill plate.

IT_ Piastra grill a pietra lavica.

ES_ Placa grill de piedra de lava.

FR_ Plaque grill en pierre de lave.

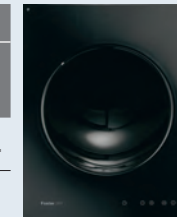

DOM12

cm 40x52
220-230V
50/60Hz

EN_ Induction glass-ceramic wok hob.

IT_ Piano cottura ad induzione wok in vetro ceramica.

ES_ Encimera wok de inducción en vitrocerámica.

FR_ Table de cuisson wok à induction en vitrocéramique.



PRO15

cm 33x53
GN 1/1 230V
3000W

EN_ Induction glass-ceramic hob - 2 cooking zones.

IT_ Piano cottura ad induzione in vitroceramica - 2 postazioni di cottura.

ES_ Placa de inducción en vitrocerámica - 2 áreas de cocción.

FR_ Plaque à induction en vitrocéramique - 2 zones de cuisson.



PRO7

cm 33x53
GN 1/1 230V
2400W

EN_ Glass-ceramic hot maintenance plate. Maximum temperature +110°C.



IT_ Piano di mantenimento del caldo in vitroceramica. Temperatura massima +110°C.

ES_ Plan de conservación del calor en vitrocerámica. Temperatura máxima +110°C.

FR_ Plan de conservation de la chaleur en vitrocéramique. Température maximale +110°C.

Appliances



PRO3
cm 33x53
GN 1/1 230/400V
6000W



EN_ Striped fry top.
Maximum temperature +250°C.

IT_ Fry top rigato.
Temperatura massima +250°C.

ES_ Placa fredora rayada. Temperatura máxima +250°C.

FR_ Fry-top rayé. Température maximale +250°C.



PRO6
cm 33x53
GN 1/1 230V
3500W



EN_ TeppanYaki plate.
Température maximum +250°C.

IT_ Piastra TeppanYaki.
Maximum temperature +250°C.

ES_ Placa TeppanYaki.
Temperatura máxima +250°C.

FR_ Plaque TeppanYaki.
Température maximale +250°C.



PRO10
cm 33x53 - lt 20
GN 1/1 230/400V
6000W

EN_ Pasta cooker.

IT_ Cuocipasta.

ES_ Cocedor de pasta.

FR_ Cuiseur à pâtes.



PRO2
cm 33x53 - lt 9
GN 1/1 230/400V
4500-6000W

EN_ Fryer.

IT_ Friggitrice.

ES_ Freidora.

FR_ Friteuse.





G6
GN 1/1
depth mm 60



EN_ Basin.

IT_ Vasca.

ES_ Tanque.

FR_ Baignoire.



K90
cm 91x35x(h)65-105
Max air expulsion capacity:
450 m³/h



EN_ Extractor hood.

IT_ Cappa ad espulsione.

ES_ Campana extractora a expulsión.

FR_ Hotte aspirante à expulsion.



K52
cm 10x52
Max air expulsion capacity:
540 m³/h



EN_ Built-in extractor hood.

IT_ Cappa integrata.

ES_ Campana extractora incorporada.

FR_ Hotte aspirante intégré.



FOR1
cm 59,5x59,4x(h)54,8
lt 71
220-240V / 3,6Kw

EN_ Built-in oven.

IT_ Forno ad incasso.

ES_ Horno empotrado.

FR_ Four intégré.



MIC1	
cm 60x50x(h)46 lt 45 220-240V -50/60Hz	
EN_	Compact microwave oven.
IT_	Forno compatto a microonde.
ES_	Horno compacto microondas.
FR_	Four à micro-ondes compact.



LAV1	
cm 40x52 depth cm 20	
EN_	Sink with foldable mixer and swiveling spout.
IT_	Lavabo con miscelatore abbattibile e canna girevole.
ES_	Fregadero con batidora plegable y caño giratorio.
FR_	Évier avec mélangeur pliant et bec pivotant.

Optionals



ANC1	
Ø cm 9 h cm 4,5	
EN_	Anchor hook.
IT_	Gancio di ancoraggio.
ES_	Gancho anclado.
FR_	Crochet d'ancorage.



P25	
cm 160	
EN_	Tempered glass protection.
IT_	Protezione in vetro temperato.
ES_	Protección de vidrio templado.
FR_	Protection en verre trempé.



P26	
cm 200	
EN_	Tempered glass protection.
IT_	Protezione in vetro temperato.
ES_	Protección de vidrio templado.
FR_	Protection en verre trempé.

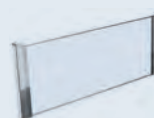

X5	
cm 60 h cm 24	
EN_	Tempered glass and 18/10 stainless steel protection.
IT_	Protezione in vetro temperato e acciaio inossidabile 18/10.
ES_	Protección en vidrio templado y acero inoxidable 18/10.
FR_	Protection en verre trempé et acier inoxydable 18/10.



T25	
cm 66x25	
EN_	Wooden cut board.
IT_	Tagliere in legno.
ES_	Tabla de cortar de madera.
FR_	Planche à découper en bois.



T26	
cm 72x25	
EN_	Wooden cut board.
IT_	Tagliere in legno.
ES_	Tabla de cortar de madera.
FR_	Planche à découper en bois.



evolution





The “evolution” of the most classic Showcooking, revisited in a collection where design, functionality and technology come together to create a professional and dynamic cooking and cocktail stations.

Designed to meet all service requirements thanks to the large worktop surface and the latest generation appliances, it represents the best solution to every gastronomic event.

IT_ L’ “evoluzione” della più classica Showcooking, rivisitato in una collezione dove design, funzionalità e tecnologia si uniscono per creare postazioni cucina e bar professionali e dinamici. Realizzata per soddisfare tutte le esigenze di servizio grazie all’ampio piano di lavoro e alle applicazioni di ultima generazione, rappresenta la migliore soluzione ad ogni evento gastronomico.

ES_ La “evolución” de la más clásica Showcooking, revisado en una colección donde el design, la funcionalidad y la tecnología se unen para crear una cocina profesional y dinámica. Diseñado para satisfacer todos los requisitos de servicio gracias a la gran superficie de trabajo y las aplicaciones de última generación, representa la mejor solución para cada evento gastronómico.

FR_ L’ “évolution” de le plus classique Showcooking, revisité dans une collection où design, fonctionnalité et technologie se conjuguent pour créer postes de cuisine et bars professionnels et dynamiques. Conçu pour répondre à toutes les exigences de service grâce à la grande surface de travail et aux applications de dernière génération, il représente la meilleure solution pour chaque événement gastronomique.



1
Sides and worktop surfaces in colour black ardesia, climb finish - B2

IT_ Lateral e piani di lavoro in colore nero ardesia, finitura climb - B2.

ES_ Lateral y encimera en colores ardesia negra, acabado climb - B2.

FR_ Latéral et plans de travail en couleurs noir ardoise, finition climb - B2.

2
Working side in colour white matt - W1.

IT_ Lato di lavoro in colore bianco matt - W1.

ES_ Lado de trabajo en colores blanco matt - W1.

FR_ Côté de travail en couleurs blanc matt - W1.

3
Customizable front panel with a wide range of colours available.

IT_ Pannello frontale personalizzabile con una vasta gamma di colori disponibili.

ES_ Panel frontal personalizable con una amplia gama de colores disponibles.

FR_ Panneau frontal personnalisable avec une large gamme de couleurs disponible.



ART. EVOLUTION 60/R1

colours available	matt finish	W1	B1	C2
	climb finish	W5	B2	C1
	ultra matt finish	W2	B6	
	wood finish	R1	Q1	A1
		E1	U1	
	mirror finish	G1	S1	

The four basic model can be customized by choosing from a wide range of appliances.

- IT_* I quattro modelli base possono essere personalizzati scegliendo tra una vasta gamma di applicazioni.
- ES_* Los cuatro modelos básicos pueden personalizarse eligiendo entre una amplia gama de aplicaciones.
- FR_* Les quatre modèles de base peuvent être personnalisés en choisissant parmi une large gamme d'applications.

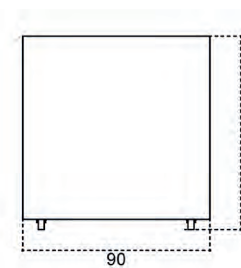
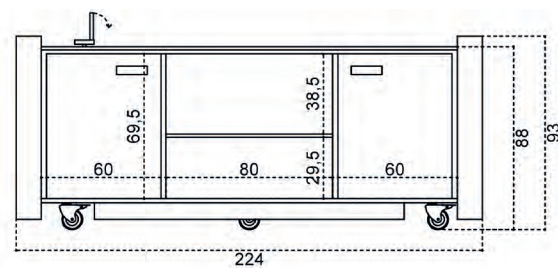
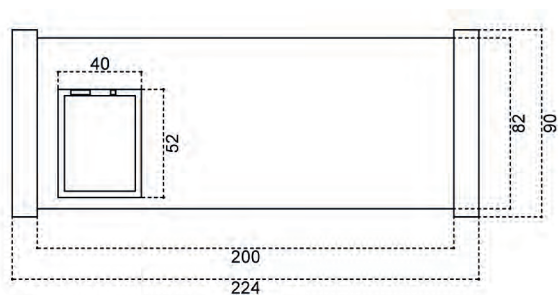

Kitchen equipped with sink, induction glass-ceramic hob and TeppanYaki plate.



- IT_* Cucina equipaggiata di lavandino, piano cottura ad induzione in vetro ceramica e piastra TeppanYaki.
- ES_* Cocina equipada con fregadero, placa de inducción en vitrocerámica y placa TeppanYaki.
- FR_* Cuisine équipée d'évier, plaque à induction en vitrocéramique et plaque TeppanYaki.



ART. EVOLUTION 60/W2/LAV1/DOM25/DOM33



BASIC MODEL: ART. EVOLUTION 60 Appliances: see pages 114-117.

EN_ Live cooking station with two doors.

IT_ Live cooking station con due ante.

ES_ Live cooking station con dos puertas.

FR_ Live cooking station avec deux portes.

Some examples

Kitchen equipped with sink, induction glass-ceramic hob and TeppanYaki plate. Built-in refrigerator included.

Refrigerator, lt 60 +10,2 - A+ - 230 Vac.



ART. EVOLUTION 61/W2/LAV1/DOM25/DOM33



BASIC MODEL: ART. EVOLUTION 61 **Appliances: see pages 114-117.**

EN_ Live cooking station with refrigerator.

IT_ Live cooking station con frigorifero.

ES_ Live cooking station con refrigerador.

FR_ Live cooking station avec réfrigérateur.

Kitchen equipped with sink, induction glass-ceramic hob and TeppanYaki plate. Built-in oven included.

Oven, 220-240V / 3,6Kw - It 71.



ART. EVOLUTION 62/B6/LAV1/DOM25/DOM33



BASIC MODEL: ART. EVOLUTION 62 **Appliances: see pages 114-117.**

EN_ Live cooking station with oven.

IT_ Live cooking station con forno.

ES_ Live cooking station con horno.

FR_ Live cooking station avec four.

Some examples

Kitchen equipped with sink, induction glass-ceramic hob and TeppanYaki plate. Built-in microwave oven included.

Microwave oven, 30 lt - 220-240V -50/60Hz.



ART. EVOLUTION 63/B6/LAV1/DOM25/DOM33



- IT_* Cucina equipaggiata di lavandino, piano cottura ad induzione in vetro ceramica e piastra TeppanYaki. Forno microonde a incasso incluso.
- ES_* Cocina equipada con fregadero, placa de inducción en vitrocerámica y placa TeppanYaki. Horno de microondas incorporado incluido.
- FR_* Cuisine équipée d'évier, plaque à induction en vitrocéramique et plaque TeppanYaki. Four à micro-ondes intégré inclus.

BASIC MODEL: ART. EVOLUTION 63 Appliances: see pages 114-117.

EN_ Live cooking station with microwaves oven.

IT_ Live cooking station con forno microonde.

ES_ Live cooking station con horno de microondas.

FR_ Live cooking station avec four à micro-ondes.



ART. LED1

Multi-coloured LED strip equipped with remote control for surprising lighting effects during evening service.

IT_ Striscia LED multicolore dotata di telecomando remoto per effetti luce sorprendenti durante il servizio serale.

ES_ Tira LED multicolor equipada con control remoto para efectos de iluminación sorprendentes durante el servicio nocturno.

FR_ Bande LED multicolore équipée d'une télécommande pour des effets de lumière surprenants pendant le service de nuit.



5 colours in one led strips.

IT_ 5 colori in un'unica striscia LED.

ES_ 5 colores en una sola tira de LED.

FR_ 5 couleurs dans une seule bande de LED.

led colours

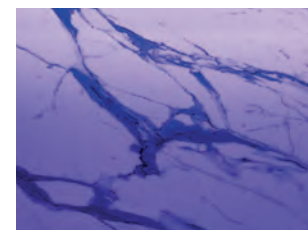
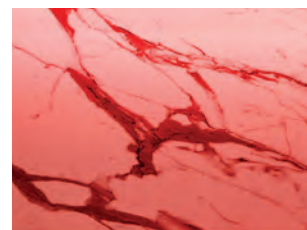
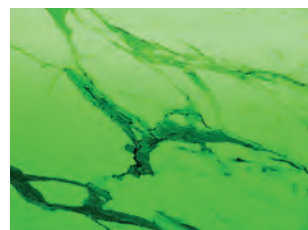

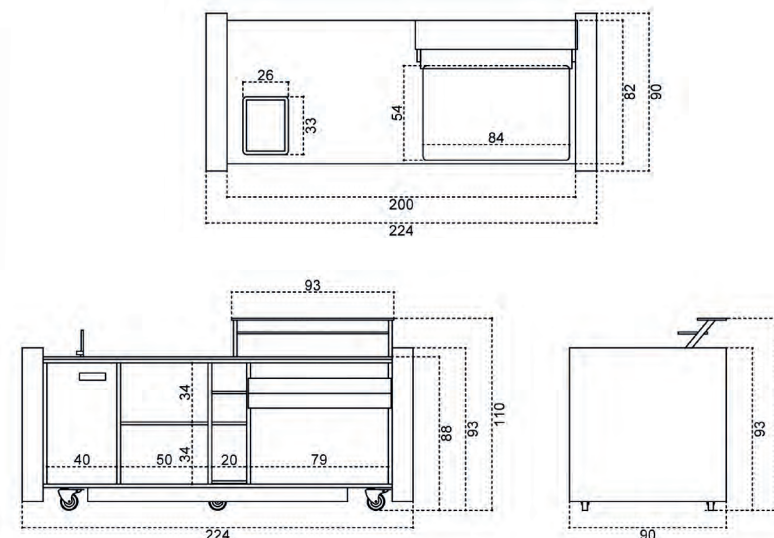

1
Worktop surfaces made with a 12 mm high pressure laminate panel.

IT_ Piani di lavoro realizzati con un pannello di laminato ad alta pressione da 12 mm.

ES_ Llano de trabajo hecho con un panel laminado de alta presión de 12 mm.

FR_ Plan de travail réalisé avec un panneau stratifié haute pression de 12 mm.

2
Professional bar basin.

IT_ Vasca cocktail professionale.

ES_ Cuenco de bar profesional.

FR_ Bassin de bar professionnel.

3
18/10-AISI 304 stainless steel washbasin with foldable mixer and swiveling spout, cm 32x35.

IT_ Lavamani in acciaio inossidabile 18/10-AISI 304 con miscelatore abbattibile e canna girevole, cm 32x35.

ES_ Fregadero en acero inoxidable 18/10-AISI 304 con grifo plegable y caño giratorio, cm 32x35.

FR_ Évier en acier inoxydable 18/10-AISI 304 avec mélangeur pliable et bec pivotant, cm 32x35.

4
Stainless steel 18/10 speed rack, cm 81x10x(h)9.

IT_ Speed rack in acciaio inossidabile 18/10, cm 81x10x(h)9.

ES_ Speed rack en acero inoxidable 18/10, cm 81x10x(h)9.

FR_ Speed rack en acier inoxydable 18/10, cm 81x10x(h)9.

5
Equipped with 6 pivoting, non-marking wheels with brakes, to facilitate service maneuvers and storage.

IT_ Muniti di 6 ruote pivotanti, antiraccia e dotate di freno, per facilitare le manovre di servizio e stoccaggio.

ES_ Equipados con 6 ruedas rotatorias, antihuella y provista de frenos para facilitar las maniobras de servicio y almacenamiento.

FR_ Equipé de 6 roues pivotantes, non marquantes avec freins, pour faciliter les manoeuvres d'entretien et stockage.

Details



EN_ Professional bar basin. Ice capacity equal to 15 kg, with drainage system that can be connected to external piping. The basin, cm 37x84x(h)55, is divided into sectors by removable panels and includes: 7 trays with lid for gaskets, removable and resealable; 2 bottle and juice separators; 1 ice separator for cubes and crushed; 1 water and drain ice separator; 1 drain with gasket.

IT_ Vasca per bar professionale. Capienza ghiaccio pari a 15 kg, con sistema di scolo collegabile alle tubazioni esterne. La vasca, cm 37x84x(h)55, è suddivisa in settori da pannelli removibili e comprende: 7 vaschette con coperchio per le guarnizioni, rimovibili e richiudibili; 2 separatori bottiglie e succhi; 1 separatore ghiaccio per cubetti e crushed; 1 separatore acqua e ghiaccio di scolo; 1 scarico con guarnizione.

ES_ Cuenco de bar profesional. Capacidad de hielo igual a 15 kg, que se puede conectar a la tubería externa. La cubeta, cm 37x84x(h)55, está dividida en sectores por paneles removibles y incluye: 7 bandejas con tapa para juntas, removibles y que se pueden volver a cerrar; 2 separadores para botellas y zumo; 1 separador de hielo para cubos y triturado; 1 separador de agua y drenaje de hielo; 1 desagüe con junta.

FR_ Baignoire de bar professionnel. Capacité de glace de 15 kg, avec système de drainage raccordable à la tuyauterie externe. Le bassin, cm 37x84x(h)55, est divisé en secteurs par des panneaux amovibles et comprend: 7 plateaux avec couvercle pour joints, amovibles et refermables; 2 séparateurs pour bouteilles et jus; 1 séparateur de glace pour les cubes et broyé; 1 séparateur d'eau et de glace de drainage; 1 drain avec joint.



EN_ Extractable glass holder.

IT_ Portabicchieri estraibile.

ES_ Portavasos extraíble.

FR_ Porte-gobelets amovible.

EN_ Stainless steel 18/10-AISI 304 speed rack. cm 81x10x(h)9.

IT_ Speed rack in acciaio inossidabile 18/10-AISI 304.

ES_ Speed rack en acero inoxidable 18/10-AISI 304.

FR_ Speed rack en acier inoxydable 18/10-AISI 304.



EN_ 18/10 stainless steel washbasin with foldable mixer and swiveling spout. Self powered. cm 32x35, depth mm 15.

IT_ Lavamani in acciaio inossidabile 18/10 con miscelatore abbattibile e canna girevole. Autoalimentato.

ES_ Fregadero en acero inoxidable 18/10 con grifo plegable y caño giratorio. Autoalimentable.

FR_ Évier en acier inoxydable 18/10 avec mélangeur pliable et bec pivotant. Autoalimenté.

Cocktail station equipped with professional instrumentation.



ART. EVOLUTION HAPPY HOURS 64/S1

IT_ Cocktail station fornita di strumentazione professionale.

ES_ Estacion cocktail equipada con herramientas profesionales.

FR_ Station de cocktails équipée d'instruments professionnels.



Cocktail station equipped with professional instrumentation. Built-in refrigerator included. Refrigerator, lt 60 +10,2 - A+ - 230 Vac.



- IT_* Una cocktail station fornita di strumentazione professionale. Frigorifero incluso.
- ES_* Una estacion cocktail equipada con herramientas profesionales. Refrigerador incorporado.
- FR_* Une station de cocktails équipée d'instruments professionnels. Réfrigérateur intégré.



ART. EVOLUTION HAPPY HOURS 65/C2



HIGH-VALUE, AESTHETICALLY APPEALING PRODUCTS WHERE
FORM NEVER COMPROMISES FUNCTION.

INTERNATIONAL AND CONTEMPORARY DESIGN WITH AN
UNMISTAKABLE STYLE.

TRADITIONAL MATERIALS LIKE WOOD AND STEEL BLEND
SEAMLESSLY WITH TECHNOLOGY, CREATING ENVIRONMENTS
THAT ARE BEAUTIFUL, PRACTICAL, AND LONG-LASTING.

FUNCTIONALITY
DESIGN
TECHNOLOGY



IT_ Prodotti di alto valore estetico ed attrattivo dove la forma non è mai a discapito della funzione. Design internazionale e contemporaneo con uno stile inconfondibile. I materiali tradizionali, come il legno e l'acciaio, si fondono alla tecnologia creando ambienti belli da vivere, pratici e duraturi.

ES_ Productos de alto valor estético y atractivo, donde la forma nunca compromete la funcionalidad. Diseño internacional y contemporáneo con un estilo único e inconfundible. Materiales tradicionales, como la madera y el acero, se integran perfectamente con la tecnología, creando entornos hermosos, prácticos y duraderos.

FR_ Produits de grande valeur esthétique et attrayants, où la forme ne compromet jamais la fonctionnalité. Design international et contemporain avec un style unique et inimitable. Les matériaux traditionnels, tels que le bois et l'acier, s'allient parfaitement à la technologie pour créer des environnements beaux, pratiques et durables.

Buffet station equipped with three 18/10-Aisi 304 stainless steel chafing dish with included 380 W electric resistance and two heated drawers for GN 1/1



- IT_* Buffet station dotato di tre chafing dish in acciaio inox 18/10-Aisi 304 con resistenza elettrica inclusa da 380 Watt e due cassette riscaldati per GN 1/1.
- ES_* Estacion de buffet equipado con tres chafing dish de acero inoxidable 18/10-Aisi 304 con resistencia eléctrica incluida de 380 Vatios y dos cajones con calefacción para GN 1/1.
- FR_* Station de buffet équipé de trois chafing dish en acier inoxydable 18/10-Aisi 304 avec résistance électrique de 380 Watt incluse et de deux tiroirs chauffants pour GN 1/1.



ART. EVOLUTION 67/W1/HOT55/CASSETTIGN1/1

Kitchen equipped with two induction cook tops, downdraft hood, refrigerated counter x 3 GN 1/1 and refrigerator



- IT_* Cucina equipaggiata con due piani di cottura a induzione, cappa downdraft, banco refrigerato per 3 GN 1/1 e frigorifero.
- ES_* Cocina equipada con dos placas de cocción por inducción, campana de extracción descendente, mueble refrigerado por 3 GN 1/1 y frigorífico.
- FR_* Cuisine équipée de deux plaques à induction, d'une hotte aspirante, d'un comptoir réfrigéré pour 3 GN 1/1 et d'un réfrigérateur.

ART. EVOLUTION 66/W1/DOM10/DOM10/COL55/K-60/FRIG

EN_ Extractor hood
IT_ Cappa aspirante
ES_ Campana extractora
FR_ Hotte aspirante

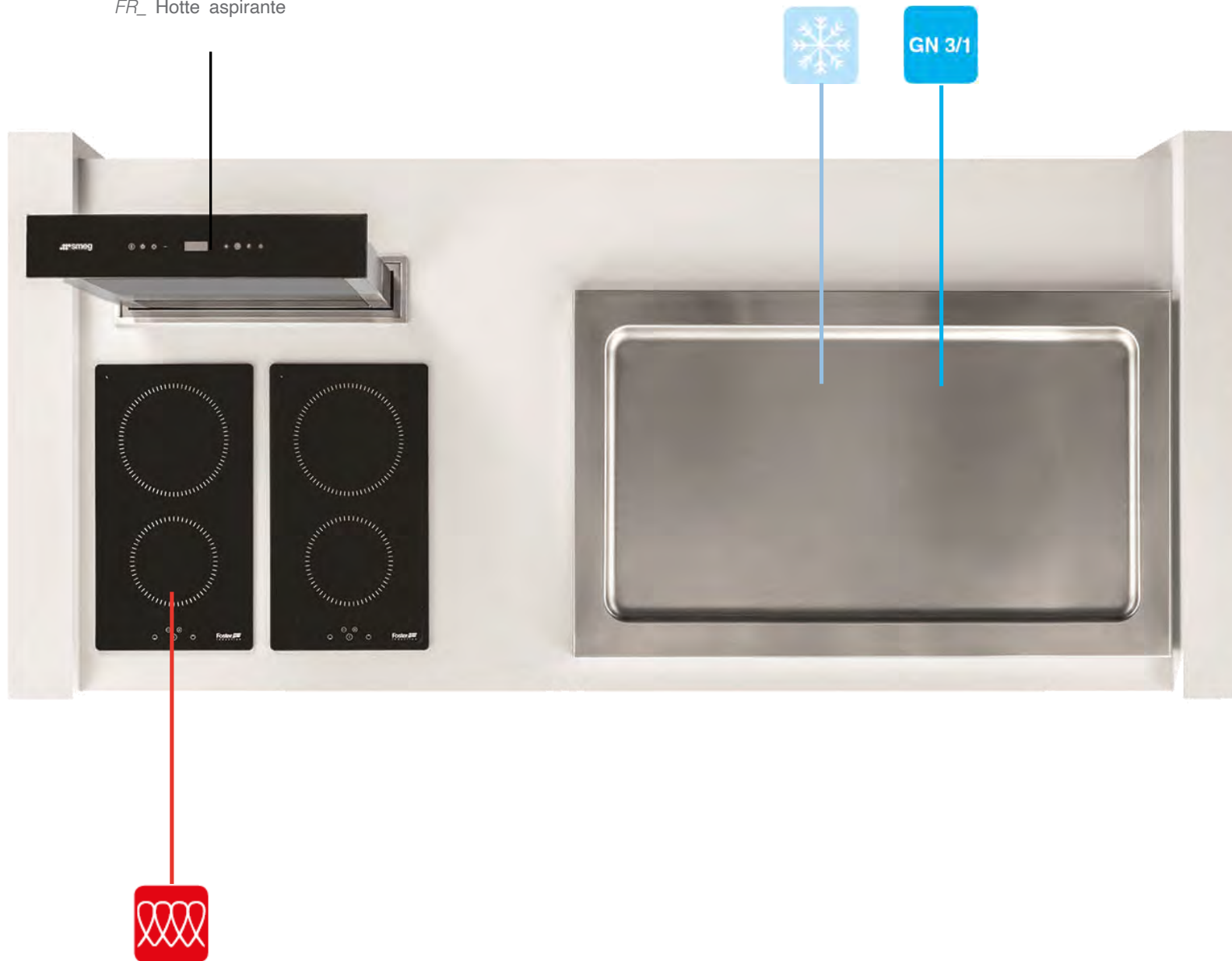

showcooking



Modern and functional lines for a fully customizable kitchen. Original and modern, it is designed for those who need functionality and simplicity enclosed in innovative, lasting and last generation materials. Its versatility allows its use in, both, indoor and outdoor environments, such as terraces, gardens or poolside, making unique your catering and meeting. Equipped with a sliding top, useful support element and serving hatch, which, once closed becomes a furniture of design.

IT_ Linee moderne e funzionali per una cucina interamente personalizzabile. Originale e moderna è ideata per chi necessita di funzionalità e semplicità racchiuse in materiali innovativi, duraturi e di ultima generazione. La sua versatilità ne permette l'utilizzo sia in ambienti interni che esterni, come terrazze, giardini o bordi piscina, rendendo unici i vostri catering e meeting. Dotata di un piano scorrevole, utile elemento di appoggio o passavivande, una volta richiusa diventa un mobile d'arredo di design.

ES_ Líneas modernas y funcionales para una cocina totalmente personalizable. Original y moderna ha sido realizada para quien necesita funcionalidad y sencillez, envuelta en materiales innovativos, durable y de ultima generación. Su versatilidad permite un empleo, ambos, en el interior como en el exterior, fueran esos terrazas, jardines o bordes de piscinas, haciendo unicos su catering y meeting. Equipada con un plano corredizo, se convierte en un útil elemento de apoyo y pasacomidas, una vez repuesta, llega a ser un precioso mueble de design.

FR_ Lignes modernes et fonctionnelles pour une cuisine entièrement personnalisable. Original et moderne, il est conçu pour ceux qui ont besoin de fonctionnalité et de simplicité dans des matériaux innovants, durables et de dernière génération. Sa polyvalence lui permet d'être utilisé à l'intérieur et à l'extérieur, comme des terrasses, des jardins ou des bordures de piscine, rendant votre restauration et vos réunions uniques. Equipé d'un plateau coulissant, un élément de support utile ou une passerelle de service, une fois fermé, il devient un élément d'ameublement design.

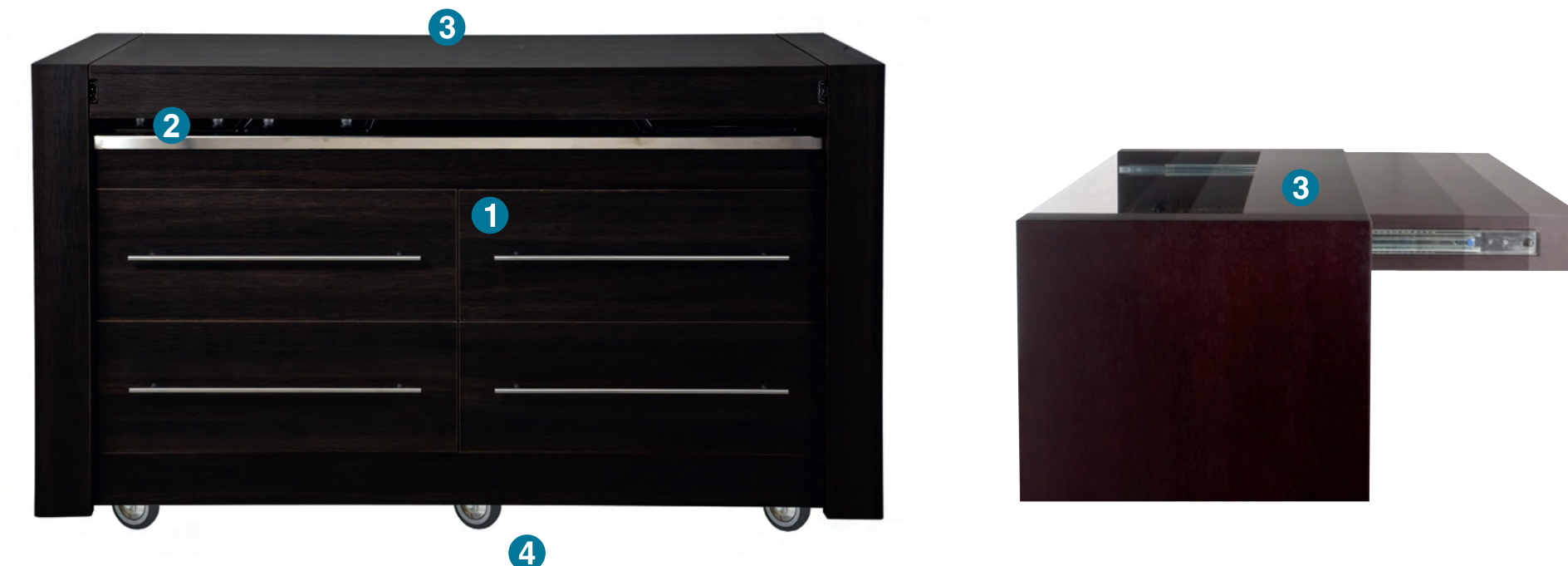

1
Made of poplar wood covered with 9/10 high pressure laminate.

IT_ Realizzati in legno di pioppo rivestito da laminato ad alta pressione da 9/10.

ES_ Hecho en madera de álamo revestido de laminado de alta presión de 9/10.

FR_ Fabriqués en bois de peuplier recouvert de stratifié haute pression de 9/10.

2
Worktop surface made of 18/10-AISI 304 stainless steel.

IT_ Piano di lavoro realizzato in acciaio inossidabile 18/10-AISI 304.

ES_ Llano de trabajo realizado en acero inoxidable 18/10-AISI 304.

FR_ Plan de travail en acier inoxydable 18/10-AISI 304.

3
Sliding top.

IT_ Piano scorrevole.

ES_ Llano corredizo.

FR_ Dessus coulissant.

4
Equipped with 6 pivoting, non-marking wheels with brakes, to facilitate service maneuvers and storage.

IT_ Muniti di 6 ruote pivotanti, antitraccia e dotate di freno, per facilitare le manovre di servizio e stoccaggio.

ES_ Equipados con 6 ruedas rotatorias, antihuella y provista de frenos, para facilitar las maniobras de servicio y almacenamiento.

FR_ Equipé de 6 roues pivotates, non marquantes avec freins, pour faciliter les manoeuvres d'entretien ed stockage.

Monocromatic: designed in a single colour version.

IT_ Monocromatica: realizzata in un'unica variante colore.

ES_ Monocromatica: creada en una unica clase de color.

FR_ Monochromatique: réalisée dans une variante de couleur unique.

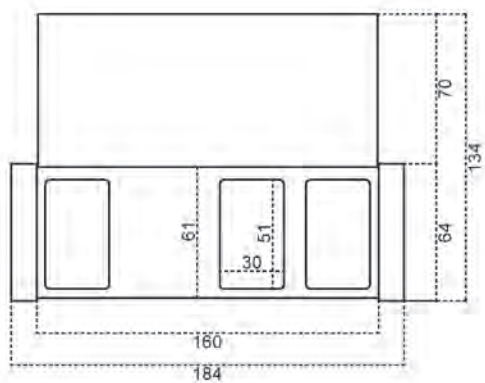

Bicromatic: designed in two different colours.

IT_ Bicromatica: realizzata con un massimo di due varianti colore.

ES_ Bicromatica: hecha en un maximo de dos diferentes colores.

FR_ Bichromatique: réalisée avec un maximum de deux variantes de couleur.

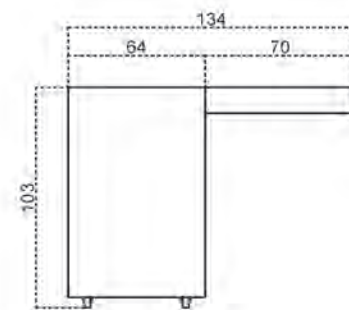
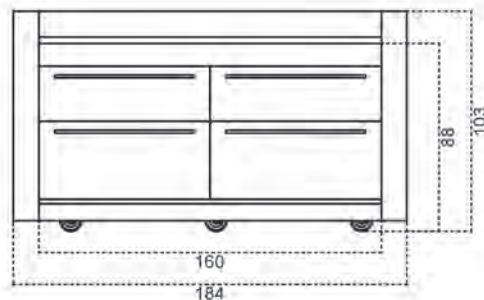

Kitchen equipped with glass-ceramic hot maintenance plate, induction hob and lava stone grill plate.



ART. SHOWCOOKING 1/R1/E1/PRO7/PRO15/DOM5

- IT_* Cucina equipaggiata di piano di mantenimento del caldo, piano cottura a induzione in vitroceramica e piastra grill a pietra lavica.
- ES_* Cocina equipada por plano de conservación del calor, placa de inducción en vitrocerámica y placa grill de piedra de lava.
- FR_* Cuisine équipée de plan de conservation de la chaleur, plaque à induction en vitrocéramique et plaque grill en pierre de lave.

colours available	matt finish	W1	B1	C2
	climb finish	W5	B2	C1
	ultra matt finish	W2	B6	
	wood finish	R1	Q1	A1
		E1	U1	
	mirror finish	G1	S1	

BASIC MODEL: ART. SHOWCOOKING 1

Appliances: see pages 114-117.

EN_ Live cooking station with four drawers.

IT_ Live cooking station con quattro cassetti.

ES_ Live cooking station con cuatro cajones. *FR_* Live cooking station avec quatre tiroirs.

Some examples

Kitchen equipped with lava stone grill plate, glass-ceramic hot maintenance plate and induction hob. Built-in oven included.

Oven, 220-240V / 3,6Kw - It 71.



ART. SHOWCOOKING 2/R1/E1/DOM5/PRO7/PRO15

BASIC MODEL: ART. SHOWCOOKING 2

Appliances: see pages 114-117.

EN_ Live cooking station with oven.

IT_ Live cooking station con forno.

ES_ Live cooking station con horno.

FR_ Live cooking station avec four.

IT_ Cucina equipaggiata di piastra grill a pietra lavica, piano di mantenimento del caldo e piano cottura a induzione in vitroceramica. Forno a incasso incluso.

ES_ Cocina equipada por placa grill de piedra de lava, plano de conservación del calor y placa de inducción en vitrocerámica. Horno empotrado incluido.

FR_ Cuisine équipée de plaque grill en pierre de lave, plan de conservation de la chaleur et plaque à induction en vitrocéramique. Four encastré inclus.

colours available	matt finish	W1	B1	C2
	climb finish	W5	B2	C1
	ultra matt finish	W2	B6	
	wood finish	R1	Q1	A1
		E1	U1	
	mirror finish	G1	S1	

Kitchen equipped with glass-ceramic hot maintenance plate and induction hob.
Built-in refrigerator included.
 Refrigerator, It 60 +10,2 - A+ - 230 Vac.



IT_ Cucina equipaggiata di piano di mantenimento del caldo e piano cottura ad induzione in vitroceramica. Frigorifero ad incasso incluso.
ES_ Cocina equipada por plan de conservación del calor y placa de inducción en vitrocerámica. Refrigerador empotrado incluido.
FR_ Cuisine équipée de plan de conservation de la chaleur et plaque à induction en vitrocéramique. Réfrigérateur encastré inclus.



ART. SHOWCOOKING 3/R1/E1/PRO7/PRO15

colours available	matt finish	W1	B1	C2
	climb finish	W5	B2	C1
	ultra matt finish	W2	B6	
	wood finish	R1	Q1	A1
		E1	U1	
	mirror finish	G1	S1	

BASIC MODEL: ART. SHOWCOOKING 3 Appliances: see pages 114-117.

EN_ Live cooking station with refrigerator. *IT_* Live cooking station con frigorifero. *ES_* Live cooking station con refrigerador. *FR_* Live cooking station avec réfrigérateur.

Kitchen equipped with sink and one GN 1/1 basin, depth mm. 60. Built-in refrigerator included. Refrigerator, lt 60 + 10,2 - A+ - 230 Vac.



ART. SHOWCOOKING OYSTER 4/Q1/B1

- IT_* Cucina equipaggiata di lavandino e vasca GN 1/1, prof. mm 60. Frigorifero a incasso incluso.
- ES_* Cocina equipada por fregadero y tanque GN 1/1, prof. mm 60. Refrigerador incorporado incluido.
- FR_* Cuisine équipée d'évier et baignoire GN 1/1, prof. mm 60. Réfrigérateur intégré inclus.



EN_ 18/10 stainless steel washbasin with foldable mixer and swiveling spout. Self powered. cm 32x35, depth mm 15.

- IT_* Lavamani in acciaio inossidabile 18/10 con miscelatore abbattibile e canna girevole. Autoalimentato.
- ES_* Fregadero en acero inoxidable 18/10 con grifo plegable y caño giratorio. Autoalimentable.
- FR_* Évier en acier inoxydable 18/10 avec mélangeur pliable et bec pivotant. Autoalimenté.

colours available							
matt finish	<table border="0"> <tr> <td> W1</td> <td> B1</td> <td> C2</td> </tr> </table>	W1	B1	C2			
W1	B1	C2					
climb finish	<table border="0"> <tr> <td> W5</td> <td> B2</td> <td> C1</td> </tr> </table>	W5	B2	C1			
W5	B2	C1					
ultra matt finish	<table border="0"> <tr> <td> W2</td> <td> B6</td> </tr> </table>	W2	B6				
W2	B6						
wood finish	<table border="0"> <tr> <td> R1</td> <td> Q1</td> <td> A1</td> </tr> <tr> <td> E1</td> <td> U1</td> <td></td> </tr> </table>	R1	Q1	A1	E1	U1	
R1	Q1	A1					
E1	U1						
mirror finish	<table border="0"> <tr> <td> G1</td> <td> S1</td> </tr> </table>	G1	S1				
G1	S1						





EN_ Professional bar basin. Ice capacity equal to 15 kg, with drainage system that can be connected to external piping. The basin, cm 84x56x(h)37, is divided into sectors by removable panels and includes: 7 trays with lid for gaskets, removable and resealable; 2 bottles and juice separators; 1 ice separator for cubes and crushed; 1 water and drain ice separator; 1 drain with gasket.

IT_ Vasca per bar professionale. Capienza ghiaccio pari a 15 kg, con sistema di scolo collegabile alle tubazioni esterne. La vasca, cm 84x56x(h)37, è suddivisa in settori da pannelli rimovibili e comprende: 7 vaschette con coperchio per le guarnizioni, rimovibili e richiudibili; 2 separatori bottiglie e succhi; 1 separatore ghiaccio per cubetti e crushed; 1 separatore acqua e ghiaccio di scolo; 1 scarico con guarnizione.

ES_ Cuenco de bar profesional. Capacidad de hielo igual a 15 kg, que se puede conectar a la tubería externa. La cubeta, cm 84x56x(h)37, está dividida en sectores por paneles removibles y incluye: 7 bandejas con tapa para juntas, removibles y que se pueden volver a cerrar; 2 separadores para botellas y zumo; 1 separador de hielo para cubos y triturado; 1 separador de agua y drenaje de hielo; 1 desagüe con junta.

FR_ Baignoire de bar professionnel. Capacité de glace de 15 kg, avec système de drainage raccordable à la tuyauterie externe. Le bassin, cm 84x56x(h)37, est divisé en secteurs par des panneaux amovibles et comprend: 7 plateaux avec couvercle pour joints, amovibles et refermables; 2 séparateurs pour bouteilles et jus; 1 séparateur de glace pour les cubes et broyé; 1 séparateur d'eau et de glace de drainage; 1 drain avec joint.



EN_ Stainless steel 18/10 speed rack. cm 81x10x(h)9.

IT_ Speed rack in acciaio inossidabile 18/10.

ES_ Speed rack en acero inoxidable 18/10.

FR_ Speed rack en acier inoxydable 18/10.

Cocktail station equipped with professional devices. Built-in refrigerator.

Refrigerator, lt 60 +10,2 - A+ - 230 Vac.



ART. HAPPY HOURS 5/Q1/W1

IT_ Una cocktail station fornita di attrezzatura professionale. Frigorifero incluso.

ES_ Una estacion cocktail equipada con herramientas profesionales. Refrigerador incorporado.

FR_ Une station de cocktails équipée d'instruments professionnels. Réfrigérateur intégré.

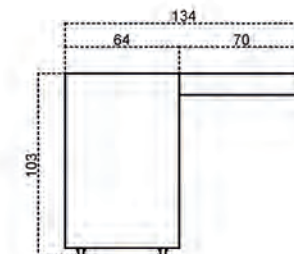
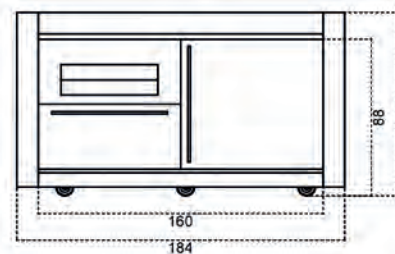
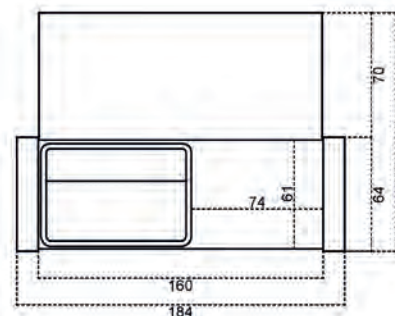

Some examples

Cocktail station equipped with professional devices. Built-in refrigerator.

Refrigerator, lt 60 +10,2 - A+ - 230 Vac.



ART. HAPPY HOURS LUX 50/W1/B2

IT_ Una cocktail station fornita di attrezzatura professionale. Frigorifero incluso.

ES_ Una estacion cocktail equipada con herramientas profesionales. Refrigerador incorporado.

FR_ Une station de cocktails équipée d'instruments professionnels. Réfrigérateur intégré.

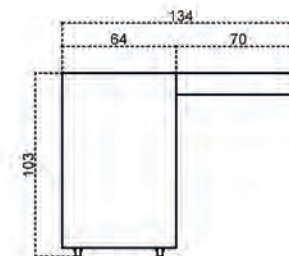
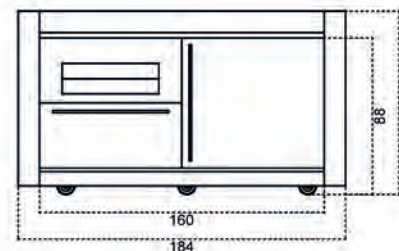
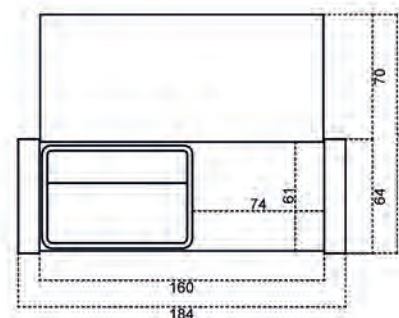

cube



Linear and elegant shapes for a furniture that integrates all the functions of a professional kitchen in a small space. Fully customizable thanks to a wide range of latest generation appliances, colours and finishes.

With this collection, the kitchen unwinds from its classic walls to open up to terraces, gardens, halls and open spaces. The kitchen is hence available everywhere.

IT_ Forme lineari ed eleganti per un mobile che racchiude tutte le funzioni di una cucina professionale in un piccolo spazio. Totalmente personalizzabile grazie ad una vasta gamma di applicazioni di ultima generazione e numerosi colori e finiture. Con questa collezione, la cucina si disancora dalle sua classiche mura per aprirsi a terrazze, giardini, sale e spazi aperti. La cucina è così a disposizione ovunque.

ES_ Formas lineales y elegantes para un mueble que integra todas las funciones de una cocina profesional en un espacio pequeño. Totalmente personalizable gracias a una amplia gama de aplicaciones de última generación y numerosos colores y acabados. Con esta colección, la cocina se desenrolla desde sus paredes clásicas para abrirse a terrazas, jardines, salas y espacios abiertos. La cocina está así disponible en todas partes.

FR_ Des formes linéaires et élégantes pour un meuble qui intègre toutes les fonctions d'une cuisine professionnelle dans un espace réduit. Totalemt personnalisable grâce à une vaste gamme d'applications de dernière génération et à de nombreuses couleurs et finitions. Avec cette collection, la cuisine se détend de ses murs classiques pour s'ouvrir sur des terrasses, des jardins, des halls et des espaces ouverts. La cuisine est tellement disponible partout.

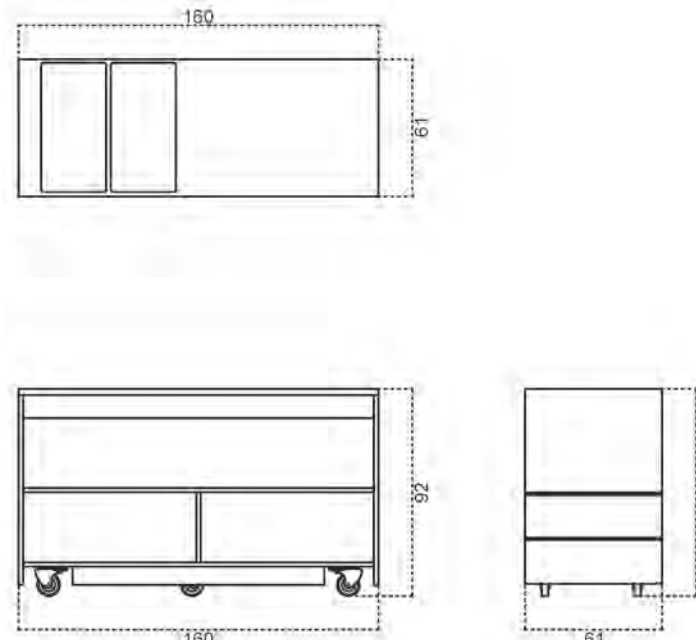

1
Made of poplar wood covered with 9/10 high pressure laminate.

IT_ Realizzati in legno di pioppo rivestito da laminato ad alta pressione da 9/10.

ES_ Hecho en madera de álamo revestido de laminado de alta presión de 9/10.

FR_ Fabriqués en bois de peuplier recouvert de stratifié haute pression de 9/10.

2
Worktop surface made of 18/10-AISI 304 stainless steel.

IT_ Piano di lavoro realizzato in acciaio inossidabile 18/10-AISI 304.

ES_ Llano de trabajo realizado en acero inoxidable 18/10-AISI 304.

FR_ Plan de travail en acier inoxydable 18/10-AISI 304.

3
Equipped with 6 pivoting, non-marking wheels with brakes, to facilitate service maneuvers and storage.

IT_ Muniti di 6 ruote pivotanti, antiraccia e dotate di freno, per facilitare le manovre di servizio e stoccaggio.

ES_ Equipado con 6 ruedas rotatorias, antihuella y provista de frenos, para facilitar las maniobras de servicio y almacenamiento.

FR_ Equipé de 6 roues pivotates, non marquantes avec freins, pour faciliter les manoeuvres d'entretien ed stockage.

Some examples

Kitchen equipped with induction glass-ceramic hob and hot maintenance plate.



ART. CUBE 63/B1/DOM25/PRO7

IT_ Cucina equipaggiata di piano cottura a induzione e piano di mantenimento del caldo in vitroceramica.

ES_ Cocina equipada de placa de inducción y plan de conservación del calor en vitrocerámica.

FR_ Cuisine équipée de plaque à induction et plan de conservation de la chaleur en vitrocéramique.

colours available	matt finish	W1	B1	C2
	climb finish	W5	B2	C1
	ultra matt finish	W2	B6	
	wood finish	R1	Q1	A1
		E1	U1	
	mirror finish	G1	S1	

BASIC MODEL: ART. CUBE 63 Appliances: see pages 114-117.

EN_ Live cooking station with three glove compartments.

IT_ Live cooking station con tre vani portaoggetti.

ES_ Live cooking station con tres guanteras.

FR_ Live cooking station avec trois compartiments de rangement.

Kitchen equipped with induction glass-ceramic hob and hot maintenance plate. Built-in refrigerator included.

Refrigerator, It 60 +10,2 - A+ - 230 Vac.



ART. CUBE 48/B1/DOM25/PRO7

- IT_* Cucina equipaggiata di piano cottura ad induzione e piano di mantenimento del caldo in vitroceramica. Frigorifero a incasso incluso.
- ES_* Cocina equipada de placa de inducción y plano de conservación del calor en vitrocerámica. Refrigerador incorporado incluido.
- FR_* Cuisine équipée de plaque à induction et plan de conservation de la chaleur en vitrocéramique. Réfrigérateur intégré inclus.

colours available	matt finish	W1	B1	C2
	climb finish	W5	B2	C1
	ultra matt finish	W2	B6	
	wood finish	R1	Q1	A1
		E1	U1	
	mirror finish	G1	S1	

BASIC MODEL: ART. CUBE 48

Appliances: see pages 114-117.

EN_ Live cooking station with refrigerator.

IT_ Live cooking station con frigorifero.

ES_ Live cooking station con refrigerador.

FR_ Live cooking station avec réfrigérateur.

Some examples

Kitchen equipped with extractor hood and two induction glass-ceramic hob.



ART. CUBE 49/E1/K60/DOM10/DOM10

BASIC MODEL: ART. CUBE 49

Appliances: see pages 114-117.

EN_ Live cooking station with three doors.

IT_ Live cooking station con tre ante.

ES_ Live cooking station con tres puertas.

FR_ Live cooking station avec trois portes.

IT_ Cucina equipaggiata di cappa ad espulsione e due piani di cottura ad induzione in vitroceramica.

ES_ Cocina equipada de campana extractora a expulsión y dos placas de inducción en vitrocerámica.

FR_ Cuisine équipée de hotte aspirante à expulsion et deux plaques à induction en vitrocéramique.



colours available	matt finish	W1	B1	C2
	climb finish	W5	B2	C1
	ultra matt finish	W2	B6	
	wood finish	R1	Q1	A1
		E1	U1	
	mirror finish	G1	S1	

Details



EN_ Two removable refrigerated drawers for easy cleaning. Equipped with soft closing.

IT_ Due cassetti refrigerati ed estraibili per facilitare la pulizia. Equipaggiati di chiusura ammortizzata.

ES_ Dos cajones refrigerados y extraíbles para facilitar la limpieza. Equipados con cierre suave.

FR_ Deux tiroir réfrigérés et amovibles pour un nettoyage facile. Équipé avec fermeture en douceur.



EN_ Refrigerator with 18/10 stainless steel top and LED backlight.

IT_ Frigorifero con piano in acciaio inossidabile 18/10 e retroilluminazione a LED.

ES_ Frigorífico con tapa de acero inoxidable 18/10 y retroiluminación LED.

FR_ Réfrigérateur avec dessus en acier inoxydable 18/10 et rétroéclairage LED.



**EN_ 18/10 stainless steel speed rack.
cm 81x10x(h)9.**

IT_ Speed rack in acciaio inossidabile 18/10.

ES_ Speed rack en acero inoxidable 18/10.

FR_ Speed rack en acier inoxydable 18/10.



EN_ Professional bar basin. Ice capacity equal to 15 kg, with drainage system that can be connected to external piping. The basin, cm 84x56x(h)37, is divided into sectors by removable panels and includes: 7 trays with lid for gaskets, removable and resealable; 2 bottle and juice separators; 1 ice separator for cubes and crushed; 1 water and drain ice separator; 1 drain with gasket.

IT_ Vasca per bar professionale. Capienza ghiaccio pari a 15 kg, con sistema di scolo collegabile alle tubazioni esterne. La vasca, cm 84x56x(h)37, è suddivisa in settori da pannelli removibili e comprende: 7 vaschette con coperchio per le guarnizioni, rimovibili e richiudibili; 2 separatori bottiglie e succhi; 1 separatore ghiaccio per cubetti e crushed; 1 separatore acqua e ghiaccio di scolo; 1 scarico con guarnizione.

ES_ Cuenco de bar profesional. Capacidad de hielo igual a 15 kg, que se puede conectar a la tubería externa. La cubeta, cm 84x56x(h)37, está dividida en sectores por paneles removibles y incluye: 7 bandejas con tapa para juntas, removibles y que se pueden volver a cerrar; 2 separadores para botellas y zumo; 1 separador de hielo para cubos y triturado; 1 separador de agua y drenaje de hielo; 1 desagüe con junta.

FR_ Baignoire de bar professionnel. Capacité de glace de 15 kg, avec système de drainage raccordable à la tuyauterie externe. Le bassin, cm 84x56x(h)37, est divisé en secteurs par des panneaux amovibles et comprend: 7 plateaux avec couvercle pour joints, amovibles et refermables; 2 séparateurs pour bouteilles et jus; 1 séparateur de glace pour les cubes et broyé; 1 séparateur d'eau et de glace de drainage; 1 drain avec joint.

Cocktail station equipped with professional instrumentation.



ART. CUBE HAPPY HOURS 42/W1/B1

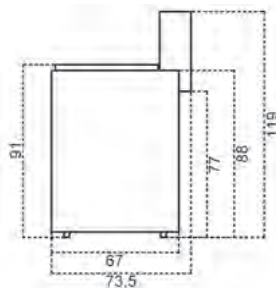
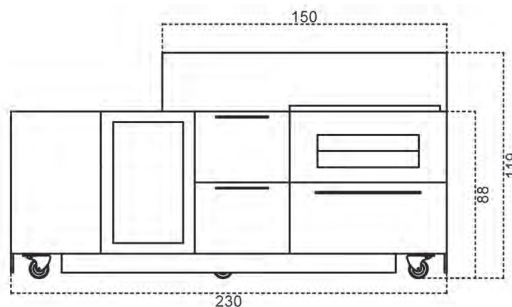

IT_ Una cocktail station fornita di strumentazione professionale.
 ES_ Una estacion cocktail equipada con herramientas profesionales.
 FR_ Une station de cocktails équipée d'instruments professionnels.



colours available	matt finish	W1	B1	C2
	climb finish	W5	B2	C1
	ultra matt finish	W2	B6	
	wood finish	R1	Q1	A1
		E1	U1	
	mirror finish	G1	S1	

new cube



The clean shapes of the Cube collection evolve to create a new design, while retaining the functionality and specialization of a professional kitchen. Thus was born NewCube.

IT_ Le linee pulite della collezione Cube si evolvono per creare un nuovo design, pur conservando la funzionalità e la specializzazione di una cucina professionale. Nasce così NewCube.

ES_ Las líneas limpias de la colección Cube se desarrollan para crear un nuevo design, aun conservando la funcionalidad y la especialización de una cocina profesional. Así nace NewCube.

FR_ Les lignes épurées de la collection Cube évoluent pour créer un nouveau design, tout en conservant les fonctionnalités et la spécialisation d'une cuisine professionnelle. Ainsi est né NewCube.



Monocromatic: designed in a single colour version.

IT_ Monocromatica: realizzata in un'unica variante colore.

ES_ Monocromatica: creada en una unica clase de color.

FR_ Monochromatique: réalisée dans une variante de couleur unique.



ART. NEW CUBE 120



ART. NEW CUBE 160

Bicromatic: designed in two different colours.

IT_ Bicromatica: realizzata con un massimo di due varianti colore.

ES_ Bicromatica: hecha en un maximo de dos diferentes colores.

FR_ Bichtomatique: réalisée avec un maximum de deux variantes de couleur.



ART. NEW CUBE 120F



ART. NEW CUBE 160F

EN_ The NewCube_Kitchen collection can be made in two sizes.

IT_ La collezione NewCube_Kitchen può essere realizzata in due misure.

ES_ La colección NewCube_Kitchen puede ser creada en dos diferentes medidas.

FR_ La collection NewCube_Kitchen peut être réalisée en deux tailles.

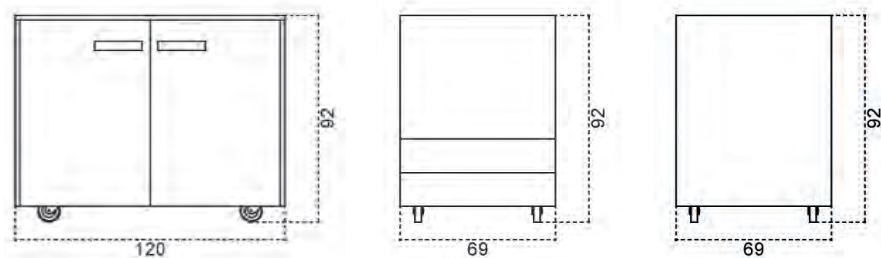

ART. NEW CUBE 120F

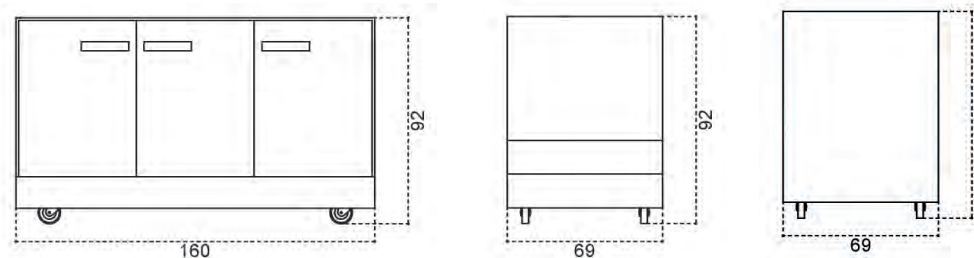

ART. NEW CUBE 160F

Kitchen equipped with sink.

Sink, cm 40x52x(h)20 - lt 22.



ART. NEW CUBE 120/W5/LAV1

IT_ Cucina equipaggiata di lavandino.

ES_ Cocina equipada con fregadero.

FR_ Cuisine équipée avec évier.

colours available	matt finish	W1	B1	C2
	climb finish	W5	B2	C1
	ultra matt finish	W2	B6	
	wood finish	R1	Q1	A1
		E1	U1	
mirror finish	G1	S1		

BASIC MODEL: ART. NEW CUBE 120 Appliances: see pages 114-117.

EN_ Live cooking station with two doors.

IT_ Live cooking station con due ante.

ES_ Live cooking station con dos puertas.

FR_ Live cooking station avec deux portes.

Some examples

Kitchen equipped with sink and glass-ceramic induction hob.

Sink, cm 40x52x(h)20 - lt 22.

Induction hob, cm 80x40 - 230V - 1,5kW.



ART. NEW CUBE 120F/W5/R1/LAV1/DOM25

IT_ Cucina equipaggiata di lavandino e piano a induzione in vetroceramica.
ES_ Cocina equipada con un fregadero y placa à inducción de vidriocerámica.
FR_ Cuisine équipée d'un évier et plaque à induction en vitrocéramique.

colours available	matt finish	W1	B1	C2
	climb finish	W5	B2	C1
	ultra matt finish	W2	B6	
	wood finish	R1	Q1	A1
		E1	U1	
	mirror finish	G1	S1	

BASIC MODEL: ART. NEW CUBE 120F Appliances: see pages 114-117.

EN_ Live cooking station with two doors.

IT_ Live cooking station con due ante.

ES_ Live cooking station con dos puertas.

FR_ Live cooking station avec deux portes.

Kitchen equipped with glass-ceramic induction hob.

Induction hob, cm 80x40 - 230V - 1,5kW.



ART. NEW CUBE 120F/W5/G1/DOM15

IT_ Cucina equipaggiata di piano ad induzione in vetroceramica.
ES_ Cocina equipada con placa inducción de vitrocerámica.
FR_ Cuisine équipée d'une plaque à induction en vitrocéramique.

colours available	matt finish	W1	B1	C2
	climb finish	W5	B2	C1
	ultra matt finish	W2	B6	
	wood finish	R1	Q1	A1
	mirror finish	G1	S1	

BASIC MODEL: ART. NEW CUBE 120F [Appliances: see pages 114-117.](#)

EN_ Live cooking station with two doors.

IT_ Live cooking station con due ante.

ES_ Live cooking station con dos puertas.

FR_ Live cooking station avec deux portes.

Some examples

Kitchen equipped with two glass-ceramic induction hobs and telescopic hood integrated in the worktop.

Induction hob, cm 80x40 - 230V - 1,5kW. Built-in extractor hood, cm 10x52 - Max air expulsion capacity: 540 m³/h.



ART. NEW CUBE 160F/B2/S1/DOM25/DOM25/K52

IT_ Cucina equipaggiata di due piani ad induzione in vetroceramica e cappa telescopica integrata nel piano di lavoro.

ES_ Cocina equipada con dos placas a inducción de vidrioocerámica y capota telescópica integrada en la encimera.

FR_ Cuisine équipée de deux plaques à induction en vitrocéramique et hotte télescopique intégrée au plan de travail.

colours available	matt finish	W1	B1	C2
	climb finish	W5	B2	C1
	ultra matt finish	W2	B6	
	wood finish	R1	Q1	A1
		E1	U1	
	mirror finish	G1	S1	

BASIC MODEL: ART. NEW CUBE 160F Appliances: see pages 114-117.

EN_ Live cooking station with three doors.

IT_ Live cooking station con tre ante.

ES_ Live cooking station con tres puertas.

FR_ Live cooking station avec trois portes.

Kitchen equipped with 18/10 stainless steel AISI 304 heating plate.

2 GN 1/1 - cm 70x58 - 220 V -800W. With two sliding doors and two internal drawers.



ART. NEW CUBE 160DW/A1/HOT52

- IT_* Cucina equipaggiata con piano caldo in acciaio inox 18/10 AISI 304. 2 GN 1/1 cm 70x58 - 220 V -800W. Con due ante scorrevoli e due cassetti interni.
- ES_* Cocina equipada con placa de cocción de acero inoxidable 18/10 AISI 304. 2 GN 1/1 cm 70x58 - 220 V -800W. Dos puertas correderas y dos cajones interiores.
- FR_* Cuisine équipée d'une plaque chauffante en acier inoxydable 18/10 AISI 304. 2 GN 1/1 cm 70x58 - 220 V -800W. Avec deux portes coulissantes et deux tiroirs intérieurs.

colours available	matt finish	W1	B1	C2
	climb finish	W5	B2	C1
	ultra matt finish	W2	B6	
	wood finish	R1	Q1	A1
	mirror finish	G1	S1	

BASIC MODEL: ART. NEW CUBE 160DW

Appliances: see pages 114-117.

EN_ Live cooking station with two inner drawers

IT_ Live cooking station con due cassetti interni.

ES_ Live cooking station con dos cajones internos.

FR_ Live cooking avec deux tiroirs intérieurs.







NEW CUBE / HIGH PRESSURE LAMINATE



All counters can be equipped with a wide range of latest generation appliances.

IT_ I banchi buffet possono essere attrezzati con una vasta gamma di applicazioni di ultima generazione.







ES_ Los mostradores de buffet pueden equiparse con una amplia gama de aplicaciones de última generación.

FR_ Les comptoirs de buffets peuvent être équipés avec une large gamme d'applications de dernière génération.







HOT MAINTENANCE	Appliances	Code	Description				Technical info	cm 120x69x(h)93	cm 160x69x(h)93
		IND51	<i>EN_</i> Induction glass-ceramic tabletop heat-retaining unit. Remote control.	<i>IT_</i> Unità di mantenimento del calore ad induzione in vetroceramica. Comando remoto.	<i>ES_</i> Unidad de mantenimiento de calor por inducción de vitrocerámica. Comando a distancia.	<i>FR_</i> Unité de chauffage par induction en vitrocéramique. Commande à distance.	cm 80x40 230V - 1,5kW	●	●
		HOT52	<i>EN_</i> 18/10-AISI 304 stainless steel heating plate. Adjustable temperature from +30 to +90°C. Remote control.	<i>IT_</i> Piano caldo in acciaio inossidabile 18/10-AISI 304. Temperatura regolabile da +30 a +90°C. Comando remoto.	<i>ES_</i> Placa calentadora en acero inoxidable 18/10-AISI 304. Temperatura regulable de +30 a +90°C. Comando a distancia.	<i>FR_</i> Plateau chauffante en acier inoxydable 18/10-AISI 304. Température réglable de +30 à +90°C. Commande à distance.	2 GN 1/1 cm 70x58(H)7 800W - 230V - 50/60Hz	●	●
		HOT59	<i>EN_</i> Tempered glass heating plate with two individually adjustable thermostats.	<i>IT_</i> Piano caldo in vetro temperato con due termostati indipendenti.	<i>ES_</i> Placa calentadora de vidrio templado con dos termostatos ajustables individualmente.	<i>FR_</i> Plateau chauffante en verre trempé avec deux thermostats à réglage individuel. Commande à distance.	cm 100x51x(H)7 600W - 230V - 50/60Hz	●	●
		HOT60	<i>EN_</i> 18/10-AISI 304 stainless steel heating plate. Adjustable temperature from +30 to +90°C. Remote control.	<i>IT_</i> Piano caldo in acciaio inossidabile 18/10-AISI 304. Temperatura regolabile da +30 a +90°C. Comando remoto.	<i>ES_</i> Placa calentadora en acero inoxidable 18/10-AISI 304. Temperatura regulable de +30 a +90°C. Comando a distancia.	<i>FR_</i> Plateau chauffante en acier inoxydable 18/10-AISI 304. Température réglable de +30 à +90°C. Commande à distance.	4 GN 1/1 103x64(h)4 1200W - 230V - 50/60Hz	●	●

ICE BASINS	Appliances	Code	Description				Technical info	cm 120x69x(h)93	cm 160x69x(h)93
		ICE57	<i>EN_</i> 18/10-AISI 304 stainless steel ice basin.	<i>IT_</i> Vasca per ghiaccio in acciaio inossidabile 18/10-AISI 304.	<i>ES_</i> Cubeta para hielo en acero inoxidable 18/10-AISI 304.	<i>FR_</i> Bac à glace en acier inoxydable 18/10-AISI 304.	2 GN 1/1 cm 41x62 depth cm 10,9	●	●
	ICE58	<i>EN_</i> 18/10-AISI 304 stainless steel ice basin.	<i>IT_</i> Vasca per ghiaccio in acciaio inossidabile 18/10-AISI 304.	<i>ES_</i> Cubeta para hielo en acero inoxidable 18/10-AISI 304.	<i>FR_</i> Bac à glace en acier inoxydable 18/10-AISI 304.	3 GN 1/1 cm 106x62 depth cm 10,9	●	●	

COLD MAINTENANCE

Appliances	Code	Description				Technical info	cm 120x69x(h)93	cm 160x69x(h)93
	COL54	EN_ Refrigerated glass-ceramic top. Adjustable temperature from -5 to +15°C.	IT_ Piano refrigerato in vetroceramica. Temperatura regolabile da -5 a +15°C.	ES_ Tapa de vidrio ceramica refrigerada. Temperatura regulable de -5 a +15°C.	FR_ Plateau en vitroc�ramique r�frig�r�. Temp�rature r�glable de -5 � +15°C.	2 GN 1/1 cm 53x66 170W - 50/60Hz		
	COL55	EN_ Refrigerated 18/10-AISI 304 stainless steel basin. Remote control.	IT_ Vasca refrigerata in acciaio inossidabile 18/10-AISI 304. Comando remoto.	ES_ Cubeta refrigerada de acero inoxidable 18/10-AISI 304. Comando a distancia.	FR_ Bac r�frig�r�e en acier inoxydable 18/10-AISI 304. Commande � distance.	3 GN 1/1 cm 106x62 350W		

PROTECTIONS

Optionals	Code	Description				Technical info	cm 120x69x(h)93	cm 160x69x(h)93
	X3	EN_ Neutral polycarbonate protection.	IT_ Protezione neutra in policarbonato.	ES_ Protecci�n neutra de policarbonato.	FR_ Protection neutre en polycarbonate.			
	Y3	EN_ Polycarbonate protection with LED lighting.	IT_ Protezione in policarbonato con illuminazione LED.	ES_ Protecci�n de policarbonato con iluminaci�n LED.	FR_ Protection en polycarbonate avec �clairage LED.	cm 100 h cm 55		
	Z3	EN_ Polycarbonate protection with heating lamp. Only to be combined with appliance Art. HOT60. See page 162.	IT_ Protezione in policarbonato con lampada riscaldante. Abbinabile solo all'applicazione Art. HOT60. Vedi pagina 162.	ES_ Protecci�n de policarbonato con l�mpara de calentamiento. Para ser combinado solo con aplicaci�n Art. HOT60. Ver p�gina 162.	FR_ Protection en polycarbonate avec lampe chauffante. Combinable seulement avec l'application Art. HOT60. Voir page 160.			

Counter equipped with 18/10-AISI 304 refrigerated basin.

3 GN 1/1 - cm 106x62x(h)3 - 350W.



ART. NEW CUBE 120F/W5/C2/COL55/X3

IT_ Banco equipaggiato di vasca refrigerata in acciaio inossidabile 18/10-AISI 304.

ES_ Mostrador equipado con cubeta refrigerada en acero inoxidable 18/10-AISI 304.

FR_ Comptoir équipé d'un bac réfrigéré en acier inoxydable 18/10-AISI 304.

colours available	matt finish	W1	B1	C2
	climb finish	W5	B2	C1
	ultra matt finish	W2	B6	
	wood finish	R1	Q1	A1
		E1	U1	
	mirror finish	G1	S1	

Optional

Neutral polycarbonate protection.

IT_ Protezione neutra in policarbonato.

ES_ Protección de policarbonato.

FR_ Protection neutre en polycarbonate.

Some examples

Counter equipped with refrigerated glass-ceramic top. 2 GN 1/1 - cm 53X66 - 170W - 50/60Hz.



ART. NEW CUBE 120F/W5/S1/COL54/X3

IT_ Banco equipaggiato di piano refrigerato in vitroceramica.
ES_ Mostrador equipado con tapa refrigerada de vitrocerámica.
FR_ Comptoir équipé de plateau en vitrocéramique réfrigéré.

colours available	matt finish	W1	B1	C2
	climb finish	W5	B2	C1
	ultra matt finish	W2	B6	
	wood finish	R1	Q1	A1
		E1	U1	
	mirror finish	G1	S1	

Optional

Neutral polycarbonate protection.

IT_ Protezione neutra in polycarbonato.

ES_ Protección de polycarbonato.

FR_ Protection neutre en polycarbonate.



Counter equipped with 18/10 stainless steel- AISI 304 heating plate. 4 GN 1/1 - cm 103x64 - +30°/+ 90°C - 1200W - 230V- 50/60Hz.



ART. NEW CUBE 120F/W5/B6/HOT60/Z3

- IT_* Banco equipaggiato di piano caldo in acciaio inossidabile 18/10-AISI 304 e protezione in policarbonato con lampada riscaldante.
- ES_* Mostrador equipado con placa calentadora de acero inoxidable 18/10-AISI 304 y protección en policarbonato con lámpara de calentamiento.
- FR_* Comptoir équipé de unité de chauffage en acier inoxydable 18/10-AISI 304 et protection en polycarbonate avec lampe chauffante.

colours available	matt finish	W1	B1	C2
	climb finish	W5	B2	C1
	ultra matt finish	W2	B6	
	wood finish	R1	Q1	A1
		E1	U1	
	mirror finish	G1	S1	

Optional

Polycarbonate protection with heating lamp.

IT_ Protezione in policarbonato con lampada riscaldante.

ES_ Protección de policarbonato con lámpara de calentamiento.

FR_ Protection en polycarbonate avec lampe chauffante.

Counter equipped with induction glass-ceramic tabletop heat-retaining unit.



ART. NEW CUBE 120F/W1/C2/IND51/X3

- IT_* Banco equipaggiato di unità di mantenimento del calore a induzione in vetroceramica.
ES_ Mostrador equipado con unidad de retención de calor a Inducion de vidrio cerámica.
FR_ Comptoir équipé d'unité de rétention de chaleur à induction en vitrocéramique.

colours available	
matt finish	W1 B1 C2
climb finish	W5 B2 C1
ultra matt finish	W2 B6
wood finish	R1 Q1 A1
	E1 U1
mirror finish	G1 S1

Optional

Neutral polycarbonate protection.

IT_ Protezione neutra in polycarbonato.

ES_ Protección de polycarbonato.

FR_ Protection neutre en polycarbonate.

Some examples

Counter equipped with tempered glass heating plate. Two individually adjustable thermostats.
cm 106x53x(h)7 - 600W - 230V - 50/60Hz.



ART. NEW CUBE 120F/W5/C1/HOT59/X3

- IT_* Banco equipaggiato di piano caldo in vetro temperato con due termostati indipendenti.
ES_ Mostrador equipado con placa calentadora de vidrio templado con dos termostatos ajustables individualmente.
FR_ Comptoir équipé de plateau chauffante en verre trempé avec deux thermostats à réglage individuel.

colours available	matt finish	W1	B1	C2
	climb finish	W5	B2	C1
	ultra matt finish	W2	B6	
	wood finish	R1	Q1	A1
		E1	U1	
mirror finish	G1	S1		

Optional

Neutral polycarbonate protection.

IT_ Protezione neutra in policarbonato.

ES_ Protección de policarbonato.

FR_ Protection neutre en polycarbonate.

naked





Naked is a collection of kitchens with simple but elegant shapes. An extremely functional product designed to meet the needs of professionals in the culinary world, it can be equipped with latest-generation appliances that make it perfect for gastronomic events.

IT_ Naked è una collezione di cucine dalle linee semplici ma eleganti. Un prodotto estremamente funzionale e studiato per soddisfare le esigenze dei professionisti del mondo culinario, può essere attrezzata con applicazioni di ultima generazione che la rendono perfetta per eventi gastronomici.

ES_ Naked es una colección de cocinas con líneas simples pero elegantes. Un producto extremadamente funcional diseñado para satisfacer las necesidades de los profesionales del mundo culinario, puede equiparse con aplicaciones de última generación que lo hacen perfecto para eventos gastronómicos.

FR_ Naked est une collection de cuisines aux lignes simples mais élégantes. Produit extrêmement fonctionnel, conçu pour répondre aux besoins des professionnels du monde culinaire, il peut être équipé d'applications de dernière génération qui le rendent parfait pour les événements gastronomiques.



ART. LED1

Multi-coloured LED strip equipped with remote control for surprising lighting effects during evening service.

IT_ Striscia LED multicolore dotata di telecomando remoto per effetti luce sorprendenti durante il servizio serale.

ES_ Tira LED multicolor equipada con control remoto para efectos de iluminación sorprendentes durante el servicio nocturno.

FR_ Bande LED multicolore équipée d'une télécommande pour des effets de lumière surprenants pendant le service de nuit.

5 colours in one led strip.

IT_ 5 colori in un'unica striscia LED.

ES_ 5 colores en una sola tira de LED.

FR_ 5 couleurs dans une seule bande de LED.

led colours



Some examples

Kitchen equipped with pasta cooker, induction glass-ceramic hob and sink.



ART. NAKED 10/R1/PRO10/PRO15

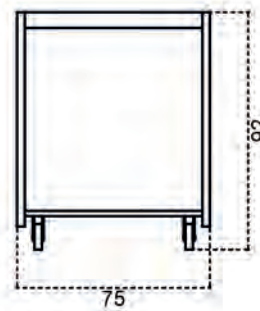
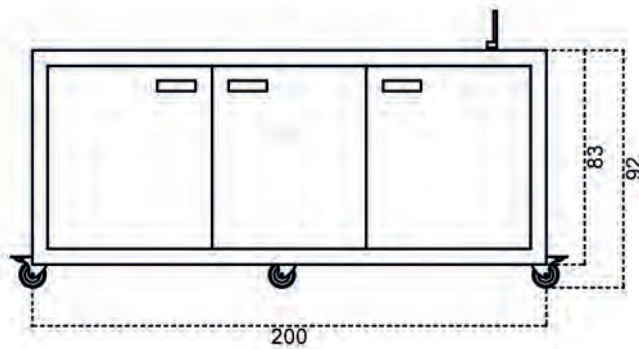

BASIC MODEL: ART. NAKED 10

Appliances: see pages 114-117.

EN_ Live cooking station with three doors and sink.

IT_ Live cooking station con tre ante e lavamani con rubinetto.

ES_ Live cooking station con tres puertas y fregadero.

FR_ Live cooking station avec trois portes et évier.

IT_ Cucina equipaggiata di cuocipasta, piano cottura a induzione in vitroceramica e lavamani.

ES_ Cocina equipada con cocedero de pasta, fregadero de inducción en vitrocerámica y fregadero.

FR_ Cuisine équipée de cuiseur à pâtes, plaque à induction en vitrocéramique et évier.

colours available	
matt finish	W1 B1
climb finish	W5 B2
wood finish	R1 Q1 A1
	E1 U1

Trolley with two removable drawers equipped with soft closing and handle.



ART. NAKED 1/R1



- IT_* Carrello con due cassetti rimovibili dotati di chiusura ammortizzata e maniglia.
- ES_* Carrito con dos cajones extraíbles equipados con cierre suave y manija.
- FR_* Chariot avec deux tiroirs extractibles équipés de fermeture en douceur et poignée.

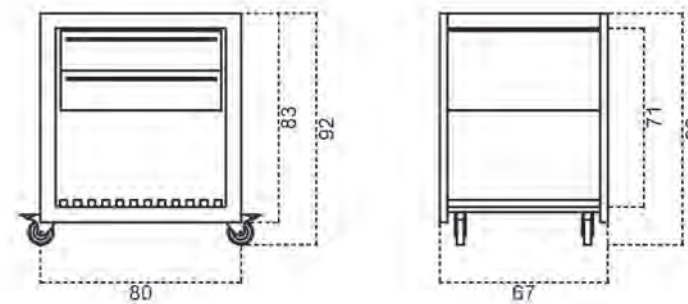

colours available	matt finish	W1	B1
	climb finish	W5	B2
	wood finish	R1	Q1
		E1	U1

Some examples

Kitchen equipped with glass-ceramic hot maintenance plate and induction hob.



ART. NAKED 6/R1/PRO7/PRO15

- IT_* Cucina equipaggiata di piano di mantenimento del caldo e piano cottura a induzione in vitroceramica.
- ES_* Cocina equipada por plan de conservación del calor y placa de inducción de vitrocerámica.
- FR_* Cuisine équipée de plan de conservation de la chaleur et plaque à induction en vitrocéramique.

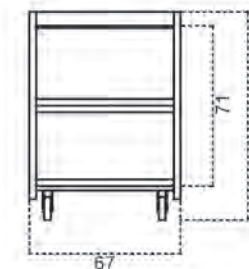
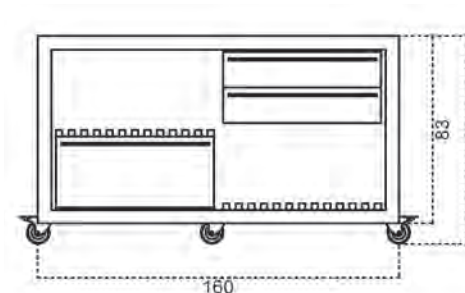

colours available	matt finish	W1	B1
	climb finish	W5	B2
	wood finish	R1	Q1
		E1	U1

BASIC MODEL: ART. NAKED 6 **Appliances: see pages 114-117.**

EN_ Live cooking station with three drawers.

IT_ Live cooking station con tre cassetti.

ES_ Live cooking station con tres cajones.

FR_ Live cooking station avec trois tiroirs.

Kitchen equipped with sink and GN 1/1 basin, depth mm. 60. Built-in refrigerator included. Refrigerator, lt 60 +10,2 - A+ - 230 Vac.



ART. NAKED OYSTER 7/W1

- IT_* Cucina equipaggiata di lavandino e vasca GN 1/1, prof. mm 60. Frigorifero ad incasso incluso.
- ES_* Cocina equipada por fregadero y tanque GN 1/1, prof. mm 60. Refrigerador incorporado incluido.
- FR_* Cuisine équipée d'évier et baignoire GN 1/1, prof. mm 60. Réfrigérateur intégré inclus.

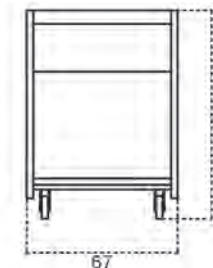
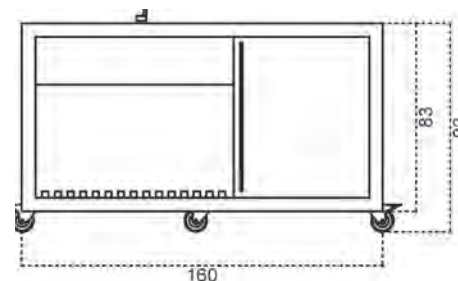

colours available	matt finish	W1	B1
	climb finish	W5	B2
	wood finish	R1	Q1
		E1	U1

Cocktail station equipped with professional instrumentation. Built-in refrigerator included. Refrigerator, lt 60 +10,2 - A+ - 230 Vac.



ART. NAKED HAPPY HOUR 8/B1

- IT_* Una cocktail station fornita di strumentazione professionale. Frigorifero incluso.
- ES_* Una estacion cocktail equipada con herramientas profesionales. Refrigerador incorporado.
- FR_* Une station de cocktails équipée d'instruments professionnels. Réfrigérateur intégré.

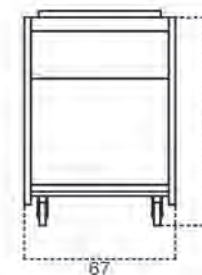
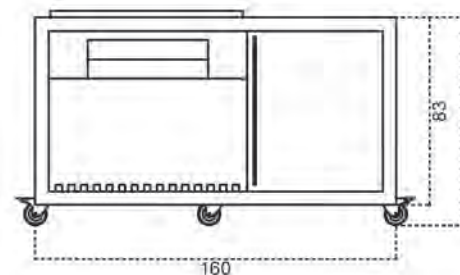

colours available

matt finish

W1

B1

climb finish

W5

B2

wood finish

R1

Q1

A1

E1

U1





Some examples

Kitchen equipped with two lava stone grill plates.



ART. NAKED 25/B1/DOM5/DOM5

IT_ Cucina equipaggiata di due piastre grill a pietra lavica.
ES_ Cocina equipada por dos placas grill de piedra de lava.
FR_ Cuisine équipée avec deux plaques grill en pierre de lave.

EN_ Wooden cut board, cm 74x25.

IT_ Tagliere in legno.
ES_ Tabla de cortar de madera.
FR_ Planche à découper en bois.

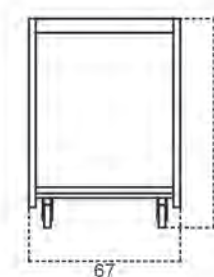
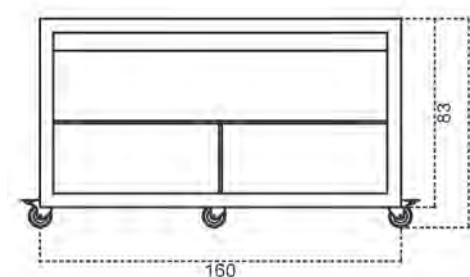

colours available	matt finish	W1	B1	C2
	climb finish	W5	B2	C1
	ultra matt finish	W2	B6	
	wood finish	R1	Q1	A1
		E1	U1	

BASIC MODEL: ART. NAKED 25 Appliances: see pages 114-117.

EN_ Live cooking station with three glove compartments.

IT_ Live cooking station con tre vani portaoggetti.

ES_ Live cooking station con tres guanteras.

FR_ Live cooking station avec trois compartiments de stockage.

Kitchen equipped with two lava stone grill plate and tempered glass protection.



ART. NAKED 26/B1/DOM5/DOM5/P25

- IT_* Cucina equipaggiata di due piastre grill a pietra lavica e protezione in vetro temperato.
ES_ Cocina equipada por dos placas grill de piedra de lava y protección en vidrio templado.
FR_ Cuisine équipée de deux plaques grill en pierre de lave et protection en verre trempé.

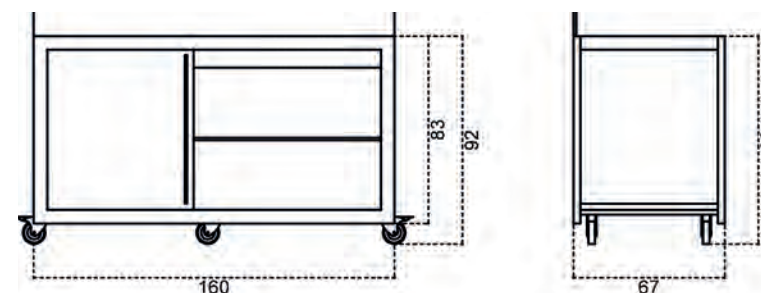

colours available	matt finish	W1	B1	C2
	climb finish	W5	B2	C1
	ultra matt finish	W2	B6	
	wood finish	R1	Q1	A1
		E1	U1	

BASIC MODEL: ART. NAKED 26

Appliances: see pages 114-117.

EN_ Live cooking station with one door and two glove compartments.

IT_ Live cooking station con un'anta e due vani portaoggetti.

ES_ Live cooking station con una puerta y dos compartimentos de almacenamiento.

FR_ Live cooking station avec une porte et deux compartiments de stockage.

Some examples

Kitchen equipped with two induction glass-ceramic hobs and tempered glass protection.



ART. NAKED 250/E1/DOM25/DOM25

- IT_* Cucina equipaggiata di due piani cottura ad induzione in vitroceramica e una protezione in vetro temperato.
- ES_* Cocina equipada por dos placas de inducción en vitrocerámica y protección de vidrio templado.
- FR_* Cuisine équipée de deux plaques à induction en vitrocéramique et protection en verre trempé.

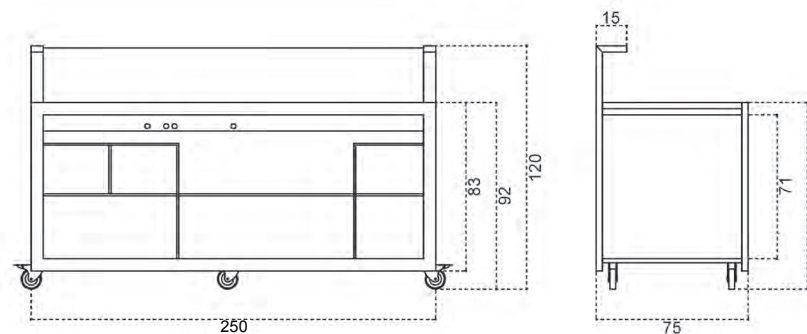

colours available	matt finish	W1	B1	C2
	climb finish	W5	B2	C1
	ultra matt finish	W2	B6	
	wood finish	R1	Q1	A1
		E1	U1	

BASIC MODEL: ART. NAKED 250

Appliances: see pages 114-117.

EN_ Live cooking station with three doors and tempered glass protection.

IT_ Live cooking station con tre ante e protezione in vetro temperato.

ES_ Live cooking station con tres puertas y protección de vidrio templado.

FR_ Live cooking station avec trois portes et une protection en verre trempé.

NAKED / HIGH PRESSURE LAMINATE

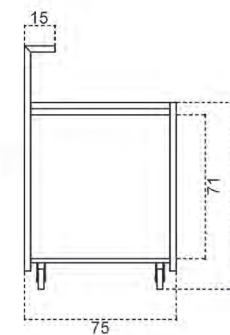
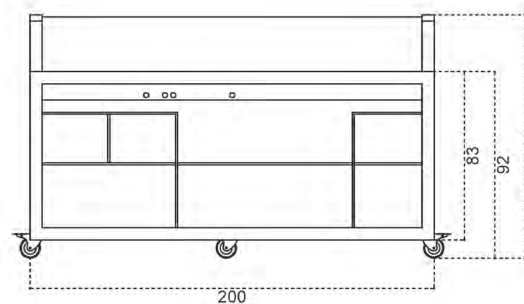
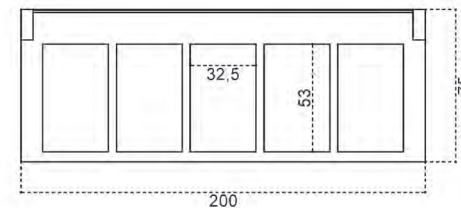

EN_ Accommodates up to 5 GN 1/1 appliances.

IT_ Ospita fino a 5 applicazioni GN 1/1.

ES_ Admite hasta 5 aplicaciones GN 1/1.

FR_ Accepte jusqu'à 5 applications GN 1/1.



EN_ Anchor hook. Ø cm 9 - h cm 4,5.

IT_ Gancio di ancoraggio.

ES_ Gancho anclado.

FR_ Crochet d'ancrage.



Some examples

Kitchen equipped with pasta cooker, infrared glass-ceramic hob, induction wok hob and tempered glass protection.



ART. NAKED 200/B1/PRO10/PRO1/PRO16

- IT_* Cucina equipaggiata di cuoci pasta, piano cottura a infrarossi in vitroceramica, piano cottura a induzione wok e protezione in vetro temperato.
- ES_* Cocina equipada con cocedero de pasta, placa de vidriocerámica infrarrojo, encimera wok de inducción y protección en vidrio templado.
- FR_* Cuisine équipé de cuiseur à pâtes, plaque en vitrocéramique à infrarouge, table de cuisson wok à induction et protection en verre trempé.



colours available	matt finish	W1	B1	C2
	climb finish	W5	B2	C1
	ultra matt finish	W2	B6	
	wood finish	R1	Q1	A1
		E1	U1	

BASIC MODEL: ART. NAKED 200 **Appliances: see pages 114-117.**

EN_ Live cooking station with 6 drawers provided with GN 1/1 plastic tray, depth mm 65 and protection in tempered glass with table top, cm 200x28.

IT_ Live cooking station con sei cassetti provvisti di vassoi GN 1/1, prof. mm 65 e protezione in vetro temperato con piano d'appoggio per piatti, cm 200x28.

ES_ Live cooking station con seis cajones provistos en bandeja de plástico GN 1/1, prof. mm 65 y protección en vidrio templado con llano de apoyo para platos, cm 200x28.

FR_ Live cooking station avec six tiroirs fournis de bac GN 1/1 en plastique, prof. mm 65 et protection en verre trempé avec surface pour assiettes, cm 200x28.

NAKED / HIGH PRESSURE LAMINATE



EN_ Accommodates up to 5 GN 1/1 appliances.

IT_ Ospita fino a 5 applicazioni GN 1/1.

ES_ Admite hasta 5 aplicaciones GN 1/1.

FR_ Accepte jusqu'à 5 applications GN 1/1.

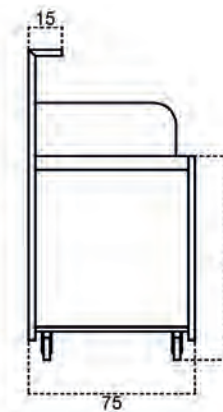
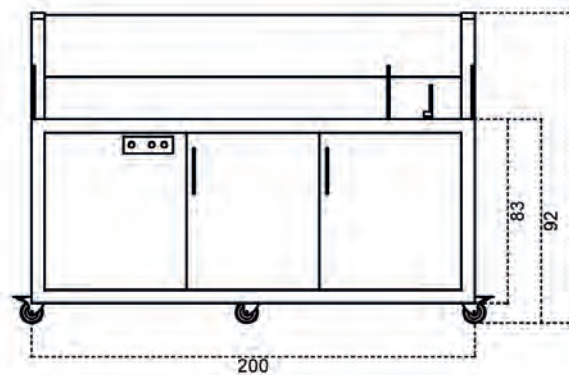
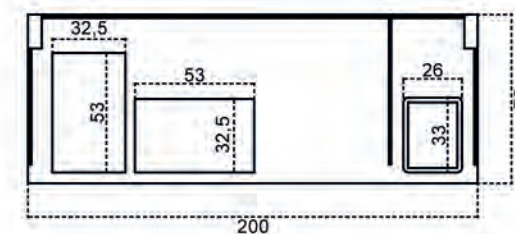

Some examples

Kitchen equipped with pasta cooker, TeppanYaki plate, handwash tank* with glass partition, cm 35-h cm 24 and protection in tempered glass with a table top for plates, cm 200x28. Complete with tempered glass side protection, cm 60-h cm 24.



ART. NAKED 150/B1/PRO10/PRO6

- IT_* Cucina equipaggiata da cuocipasta, piastra TeppanYaki, lavamani* con separatore in vetro, cm 35-h cm 24 e protezione in vetro temperato con piano d'appoggio per piatti, cm 200x28. Completo di protezione laterale in vetro temperato, cm 60-h cm 24.
- ES_* Cocina equipada por cocedero de pasta, placa TeppanYaki, lavadero* con separador de vidrio, cm 35-h cm 24 y protección en vidrio templado con llano de apoyo para platos, cm 200x28. Completo con protección lateral de vidrio templado, cm 60-h cm 24.
- FR_* Cuisine équipée de cuiseur à pâtes, plaque TeppanYaki, lave-mains* avec séparateur de verre, cm 35-h cm 24 et protection en verre trempé avec plateau pour assiettes, cm 200x28. Complet avec protection latérale en verre trempé, cm 60-h cm 24.

*

EN_ On request, available with connection to the external water supply.

IT_ Su richiesta, disponibile con collegamento alla rete idrica esterna.

ES_ A pedido, disponible con conexión al suministro externo de agua.

FR_ Sur demande, disponible avec raccordement à l'alimentation en eau externe.

colours available	matt finish	W1	B1	C2
	climb finish	W5	B2	C1
	ultra matt finish	W2	B6	
	wood finish	R1	Q1	A1
		E1	U1	

BASIC MODEL: ART. NAKED 150 Appliances: see pages 114-117.

EN_ Live cooking station with three doors, tempered glass protection and side protection. Complete with handwash tank.

IT_ Live cooking station con tre ante, protezione e protezione laterale in vetro temperato. Completa di lavamani.

ES_ Live cooking station con tres puertas, protección y protección lateral en vidrio templado. Completa con lavadero.

FR_ Live cooking station avec trois portes, protection et protection laterale en verre trempé. Complete avec lave-mains.

NAKED / HIGH PRESSURE LAMINATE

EN_ Accommodates up to 4 GN 1/1 appliances.

IT_ Ospita fino a 4 applicazioni GN 1/1.

ES_ Admite hasta 4 aplicaciones GN 1/1.

FR_ Accepte jusqu'à 4 applications GN 1/1.

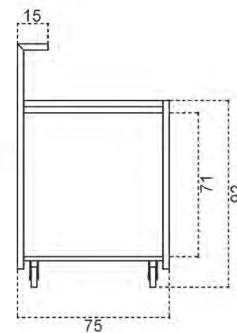
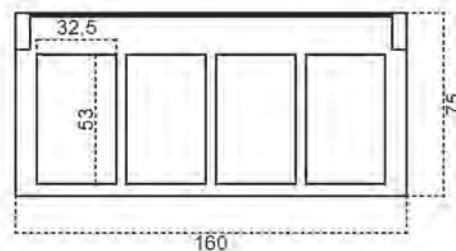

Some examples

Kitchen equipped with protection in tempered glass with table top, cm 160x28, glass-ceramic hot maintenance plate and TeppanYaki plate.



ART. NAKED 160/B1/PRO7/PRO6

- IT_* Cucina equipaggiata con protezione in vetro temperato con piano d'appoggio per piatti, cm 160x28, piano di mantenimento del caldo in vitroceramica e piastra TeppanYaki.
- ES_* Cocina equipada con protección en vidrio templado con tablero de mesa, cm 160x28, plano de conservación del calor en vitrocerámica y placa TeppanYaki.
- FR_* Cuisine équipée de protection en verre trempé avec plateau, cm 160x28, plan de conservation de la chaleur en vitrocéramique et plaque TeppanYaki.

colours available	matt finish	W1	B1	C2
	climb finish	W5	B2	C1
	ultra matt finish	W2	B6	
	wood finish	R1	Q1	A1
		E1	U1	

BASIC MODEL: ART. NAKED 160 **Appliances: see pages 114-117.**

EN_ Live cooking station with one door and tempered glass protection.

IT_ Live cooking station con un'anta e protezione in vetro temperato.

ES_ Live cooking station con una puerta y protección de vidrio templado.

FR_ Live cooking station avec une porte et protection en verre trempé.

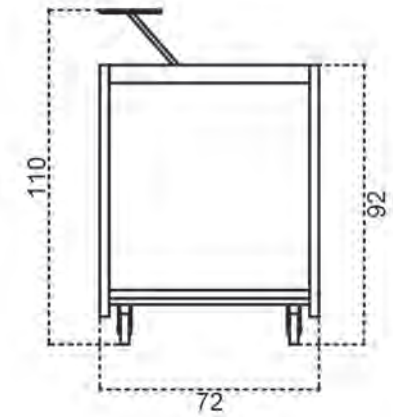
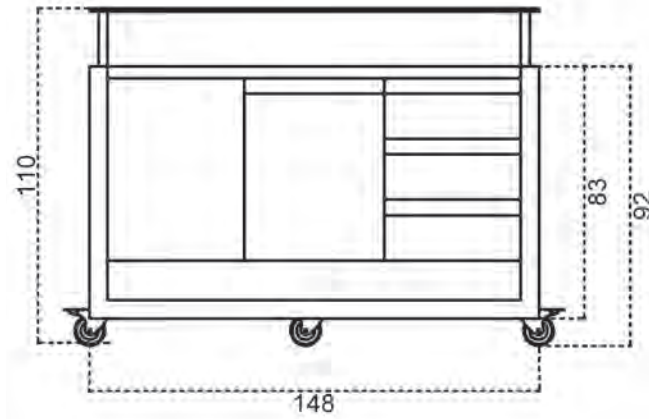
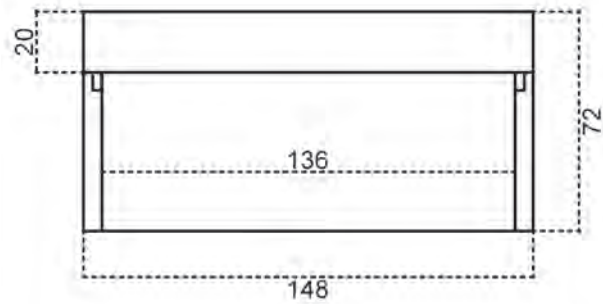

Details



- EN_ Two removable refrigerated drawers for easy cleaning. Equipped with soft closing.**
- IT_* Due cassetti refrigerati ed estraibili per facilitare la pulizia. Equipaggiati di chiusura ammortizzata.
- ES_* Dos cajones refrigerados y extraibles para facilitar la limpieza. Equipados con cierre suave.
- FR_* Deux tiroir réfrigérés et amovibles pour un nettoyage facile. Équipé avec fermeture en douceur.



- EN_ Built-in refrigerator. Adjustable temperature from -2 to +8°C. 230V - 50Hz.**
- IT_* Frigorifero ad incasso.
- ES_* Nevera empotrada.
- FR_* Réfrigérateur intégré.

Optional ①

Service shelf. cm 148x20.

IT_ Piano di servizio.

ES_ Llano de servicio.

FR_ Plan de service.

Kitchen equipped with refrigerated drawers and professional refrigerator with forced ventilation system.



ART. NAKED 27/B1

- IT_* Cucina equipaggiata da cassetti refrigerati e frigorifero professionale con sistema di ventilazione forzata.
- ES_* Cocina equipada por cajones refrigerados y refrigerador profesional con sistema de ventilación forzada.
- FR_* Cuisine équipée de tiroirs réfrigérés et réfrigérateur professionnel avec système de ventilation forcée.



colours available	matt finish	W1	B1	C2
	climb finish	W5	B2	C1
	ultra matt finish	W2	B6	
	wood finish	R1	Q1	A1
		E1	U1	

LIFESTYLE MOVING EXPERIENCE

EN_ The diversified range of products Deagostini Inox aims to respect some essential manufacturing principles. Their indispensable functionality is harmoniously combined with a cutting-edge design, which never neglects the latest generation technology. This is how our products come to life beautiful, practical, durable and guaranteed “Made in Italy”.

IT_ La gamma diversificata dei prodotti Deagostini Inox si propone di rispettare alcuni principi fondamentali di manifattura. La loro imprescindibile funzionalità si accosta armoniosamente ad un design d'avanguardia, che mai trascurava la tecnologia di ultima generazione. Nascono così i nostri prodotti, belli da vivere, pratici, duraturi e garantiti “Made in Italy”.

ES_ La gama diversificada de los productos Deagostini Inox es creada para respetar algunos principios esenciales de manufactura. La loro imprescindible funcionalidad se acerca armoniosamente a un design de vanguardia, que nunca deja a medias la tecnología de última generación. Nacen así nuestros productos, bellos en vivirlos, prácticos, y garantizado “Made in Italy”.

FR_ La gamme diversifiée de produits Deagostini Inox vise à respecter certains principes de fabrication fondamentaux. Leur essentielle fonctionnalité est harmonieusement combinée avec un design de pointe, qui ne néglige jamais les technologies de dernière génération. C'est ainsi que nos produits prennent vie, beaux, pratiques, durables et garantis “Made in Italy”.





SKILLS. DESIGN. PASSION.

EN_ Six collections of buffet systems, tradition of Deagostini Inox manufacturing, revisited and revolutionized to transform each device into a functional and design tool. The wide range available offers not only the essential tools of a buffet service, but also lots of solutions for hot and cold maintenance, with the chance of creating endless combinations of customization.

Our sales department will be happy to assist you in creating a customized project!

IT_ Sei collezioni di linee buffet, tradizione della manifattura Deagostini Inox, rivisitate e rivoluzionate per trasformare ogni dispositivo in uno strumento funzionale e di design. La vasta gamma a disposizione offre, non solo gli essenziali strumenti del servizio buffet, ma anche numerose soluzioni per il mantenimento del caldo e del freddo, con la possibilità di creare infinite combinazioni di personalizzazione.

Il nostro ufficio vendite sarà lieto di assistervi nella creazione di un progetto su misura!



Ask for our "Lifestyle" catalogue.

+LUX

EN_ Innovative materials combined with mirror finish stainless steel or a unique design, strong aesthetic appeal and sophisticated style.

IT_ Materiali innovativi accompagnati dall'acciaio inossidabile lucidato a specchio per un design unico, forte appeal estetico e stile raffinato.



SHINY STEEL

EN_ Stainless steel embellished by the shine of the mirror finish or a rigorous, clean and light collection. A modern design that does not forget the needs of professional comfort.

IT_ L'acciaio inossidabile impreziosito dalla finitura a specchio per una collezione rigorosa, pulita e leggera. Un design moderno che non prescinde dalle esigenze di comfort professionale.



TRUE STEEL

EN_ Reliability, durability and tradition. A modular and functional design with strict rules of attention to materials.

IT_ Affidabilità, durevolezza e tradizione. Un design componibile e funzionale con rigorose regole di attenzione ai materiali.



BLACK

EN_ Black wood, colour of elegance and refinement. Lava stone, a unique material in modern culinary innovation.

IT_ Il legno nero, colore di eleganza e raffinatezze. La pietra lavica, un materiale unico nell'innovazione culinaria moderna.



MY WOOD

EN_ A reinterpretation of wood in a contemporary and functional way, warm and passionate.

IT_ Una rivisitazione del legno in veste contemporanea e funzionale, calda e appassionata.



GLASSY

EN_ The glass give life to a fully customizable collection that can satisfy the needs of space and exposure.

IT_ Il vetro dà vita ad una collezione interamente personalizzabile che può soddisfare tutte le esigenze di spazio ed esposizione.



MODULARITY. ADAPTABILITY. FUNCTIONALITY.

EN_ All Deagostini Inox trolleys collections are represented by modular products, easy to transport and maintain, made with progressive, resistant, durable and strong materials. The wide range of colour finishes allow an easily set of our product in any environment. While the several optionals available allow the transformation of a trolley into a real mobile kitchen.

IT_ Tutte le collezioni dei carrelli Deagostini Inox sono rappresentate da prodotti interamente modulari, di facile trasporto e manutenzione, con materiali innovativi, resistenti e duraturi. Le numerose finiture di colore tra cui scegliere permettono di inserire facilmente il nostro prodotto ad ogni ambiente. I numerosi optional a disposizione consentono infine la trasformazione di un carrello in una vera e propria cucina mobile.



Ask for our "Moving" catalogue.

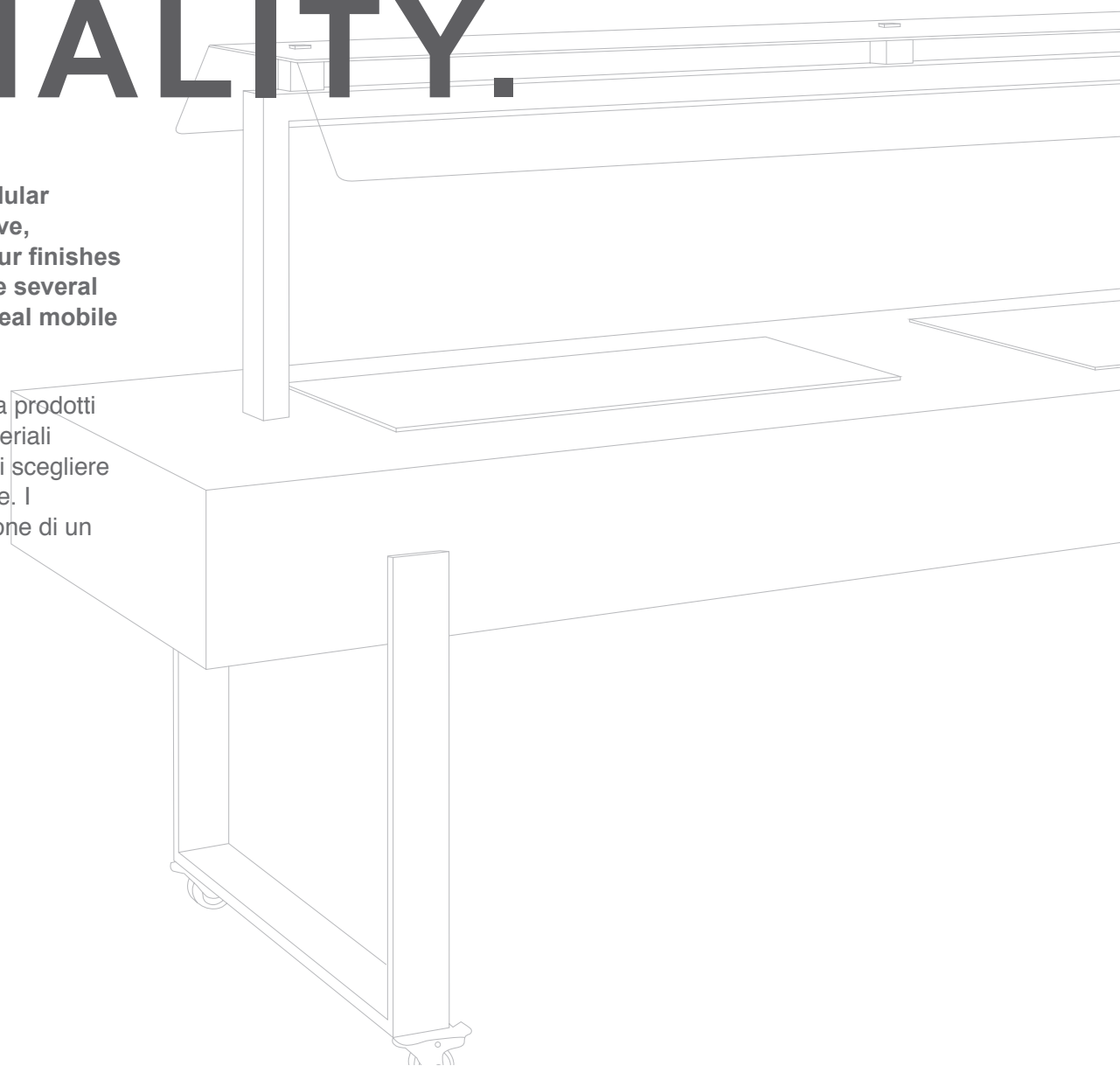

LUX

EN_ Collection of independent and autonomous modular system that combine the latest generation appliances and functionality with their elegant and essential style.

IT_ Una collezione di sistemi modulari ed autonomi che combinano al loro stile elegante ed essenziale applicazioni di ultima generazione, nonché funzionalità.



CROSS FRAME OPEN

EN_ Modern, elegant and functional trolleys collection. Their simplicity makes them the ideal product to adapt to any environment and satisfy any need.

IT_ Collezione di carrelli moderna, elegante e funzionale. La loro semplicità li rende il prodotto ideale per adattarsi ad ogni ambiente e soddisfare qualsiasi necessità.



WOOD

EN_ A reinterpretation of wood in a contemporary and functional way, warm and passionate. A fine manufacture that makes both trolleys and dining room furniture an ideal furnishing complement as they are made with passion and competence.

IT_ Una rivisitazione del legno in veste contemporanea e funzionale, calda e appassionata. Una fine manifattura che rende sia i carrelli che i mobili da sala un complemento d'arredo ideale.



PASTRY

EN_ A collection entirely dedicated to the world of pastry and desserts.

IT_ Una collezione interamente dedicata al mondo della pasticceria e dei dolci.





Ask for our Lifestyle catalogue or find it her .





Many thanks to:

Villa Nigra, Miasino - Parco le Cicogne, Barengo - Hotel Cortese, Armeno - Hotel San Rocco, Orta San Giulio - Calathea, Pettenasco.

EN_ Deagostini Inox S.r.l. reserves the right to make any changes to its products deemed useful for the qualitative improvement of the same, both dimensional and structural. Sales conditions are available upon request. All parts and materials with food contact have been tested and approved for food contact.

All rights reserved - © Deagostini Inox S.r.l.

IT_ Deagostini Inox S.r.l. si riserva il diritto di apportare ai propri prodotti qualsiasi modifica ritenuta utile al miglioramento qualitativo degli stessi, sia dimensionale che strutturale. Le nostre condizioni commerciali sono disponibili su richiesta. Tutti i componenti ed i materiali a contatto con gli alimenti sono stati testati e approvati come idonei ad uso alimentare.

Tutti i diritti riservati - © Deagostini Inox S.r.l.



DEAGOSTINI INOX S.R.L.

Via Comoli, 93/A
28887 Omegna (VB) - ITALY

+39 0323 862804

+39 0323 862991

info@deagostini-inox.it

www.deagostini-inox.com

